



Nipples
PVC, CPVC & PE Nipples

PVC, CPVC & PE Nipples



PRICING



Nipples PVC, CPVC & PE Nipples



- PVC/CPVC Nipples furnished may be produced from extruded stock, or from molding grade PVC/CPVC compounds. Both processes provide quality products meeting ASTM requirements.
- Half Size Nipples not shown are priced the same as the next full size.
For example: 7-1/2" is priced the same as 8".
- CONTACT YOUR LOCAL SPEARS® REPRESENTATIVE FOR PRICE AND AVAILABILITY OF SIZES, LENGTHS, AND/OR CONFIGURATIONS NOT SHOWN.

PVC Schedule 80 Nipple

Size	Threaded Both Ends	Threaded One End	Plain End	Std Pk	Mstr Pk	Prod Code
1/8" Diameter						
1/8XCLOSE	879-005 1.18	1879-005 1.18	879-005P 1.18	25	800	120
1/8X1-1/2	879-015 1.18	1879-015 1.18	879-015P 1.18	25	800	120
1/8X2	879-020 1.34	1879-020 1.34	879-020P 1.34	25	800	120
1/8X2-1/2	879-025 1.41	1879-025 1.41	879-025P 1.41	25	800	120
1/8X3	879-030 1.41	1879-030 1.41	879-030P 1.41	25	800	120
1/8X3-1/2	879-035 1.56	1879-035 1.56	879-035P 1.56	25	800	120
1/8X4	879-040 1.56	1879-040 1.56	879-040P 1.56	25	800	120
1/8X4-1/2	879-045 1.76	1879-045 1.76	879-045P 1.76	25	600	120
1/8X5	879-050 1.76	1879-050 1.76	879-050P 1.76	25	600	120
1/8X5-1/2	879-055 2.01	1879-055 2.01	879-055P 2.01	25	600	120
1/8X6	879-060 2.01	1879-060 2.01	879-060P 2.01	25	600	120
1/8X7	879-070 2.34	1879-070 2.34	879-070P 2.34	25	450	120
1/8X8	879-080 2.65	1879-080 2.65	879-080P 2.65	25	600	120
1/8X9	879-090 2.79	1879-090 2.79	879-090P 2.79	25	400	120
1/8X10	879-100 3.20	1879-100 3.20	879-100P 3.20	25	400	120
1/8X11	879-110 3.47	1879-110 3.47	879-110P 3.47	25	400	120
1/8X12	879-120 3.47	1879-120 3.47	879-120P 3.47	25	400	120
1/8X13	879-130 4.48	1879-130 4.48	879-130P 4.48	25	400	120
1/8X14	879-140 4.89	1879-140 4.89	879-140P 4.89	25	250	120
1/8X15	879-150 5.14	1879-150 5.14	879-150P 5.14	25	300	120
1/8X16	879-160 5.68	1879-160 5.68	879-160P 5.68	25	250	120
1/8X17	879-170 5.91	1879-170 5.91	879-170P 5.91	25	250	120
1/8X18	879-180 6.07	1879-180 6.07	879-180P 6.07	25	0	120
1/8X19	879-190 6.46	1879-190 6.46	879-190P 6.46	5	0	120
1/8X20	879-200 6.89	1879-200 6.89	879-200P 6.89	25	0	120
1/8X22	879-220 7.35	1879-220 7.35	879-220P 7.35	25	0	120
1/8X24	879-240 8.02	1879-240 8.02	879-240P 8.02	25	0	120
1/8X30	879-300 10.22	1879-300 10.22	879-300P 10.22	25	0	120
1/8X36	879-360 12.04	1879-360 12.04	879-360P 12.04	25	0	120
1/8X42	879-420 14.02	1879-420 14.02	879-420P 14.02	25	0	120
1/8X48	879-480 16.03	1879-480 16.03	879-480P 16.03	25	0	120
1/4" Diameter						
1/4XCLOSE	880-005 1.23	1880-005 1.23	880-005P 1.23	25	1200	120

PVC Schedule 80 Nipple (continued)

Size	Threaded Both Ends	Threaded One End	Plain End	Std Pk	Mstr Pk	Prod Code
1/4" Diameter						
1/4X1-1/2	880-015 1.23	1880-015 1.23	880-015P 1.23	25	1200	120
1/4X2	880-020 1.51	1880-020 1.51	880-020P 1.51	25	500	120
1/4X2-1/2	880-025 1.51	1880-025 1.51	880-025P 1.51	25	500	120
1/4X3	880-030 2.01	1880-030 2.01	880-030P 2.01	25	550	120
1/4X3-1/2	880-035 2.01	1880-035 2.01	880-035P 2.01	25	500	120
1/4X4	880-040 2.34	1880-040 2.34	880-040P 2.34	25	300	120
1/4X4-1/2	880-045 2.34	1880-045 2.34	880-045P 2.34	25	250	120
1/4X5	880-050 2.54	1880-050 2.54	880-050P 2.54	25	250	120
1/4X5-1/2	880-055 2.54	1880-055 2.54	880-055P 2.54	25	250	120
1/4X6	880-060 2.65	1880-060 2.65	880-060P 2.65	25	250	120
1/4X7	880-070 2.74	1880-070 2.74	880-070P 2.74	25	250	120
1/4X8	880-080 2.89	1880-080 2.89	880-080P 2.89	25	250	120
1/4X9	880-090 2.97	1880-090 2.97	880-090P 2.97	25	250	120
1/4X10	880-100 3.04	1880-100 3.04	880-100P 3.04	25	250	120
1/4X11	880-110 3.26	1880-110 3.26	880-110P 3.26	25	250	120
1/4X12	880-120 3.59	1880-120 3.59	880-120P 3.59	25	250	120
1/4X13	880-130 5.22	1880-130 5.22	880-130P 5.22	25	250	120
1/4X14	880-140 5.26	1880-140 5.26	880-140P 5.26	25	250	120
1/4X15	880-150 5.58	1880-150 5.58	880-150P 5.58	25	500	120
1/4X16	880-160 7.02	1880-160 7.02	880-160P 7.02	25	250	120
1/4X17	880-170 7.38	1880-170 7.38	880-170P 7.38	25	300	120
1/4X18	880-180 7.53	1880-180 7.53	880-180P 7.53	25	300	120
1/4X19	880-190 7.89	1880-190 7.89	880-190P 7.89	25	300	120
1/4X20	880-200 8.01	1880-200 8.01	880-200P 8.01	25	200	120
1/4X22	880-220 8.38	1880-220 8.38	880-220P 8.38	25	300	120
1/4X24	880-240 8.53	1880-240 8.53	880-240P 8.53	25	200	120
1/4X30	880-300 10.47	1880-300 10.47	880-300P 10.47	25	0	120
1/4X36	880-360 12.68	1880-360 12.68	880-360P 12.68	25	0	120
1/4X42	880-420 14.92	1880-420 14.92	880-420P 14.92	25	0	120
1/4X48	880-480 16.59	1880-480 16.59	880-480P 16.59	25	0	120
3/8" Diameter						
3/8XCLOSE	881-005 1.28	1881-005 1.28	881-005P 1.28	25	800	120
3/8X1-1/2	881-015 1.28	1881-015 1.28	881-015P 1.28	25	800	120



Nipples PVC, CPVC & PE Nipples

PVC Schedule 80 Nipple (continued)

Size	Threaded Both Ends	Threaded One End	Plain End	Std Pk	Mstr Pk	Prod Code
1/4" Diameter						
1/4X36	880-360 12.68	1880-360 12.68	880-360P 12.68	25	0	120
1/4X42	880-420 14.92	1880-420 14.92	880-420P 14.92	25	0	120
1/4X48	880-480 16.59	1880-480 16.59	880-480P 16.59	25	0	120

3/8" Diameter

3/8XCLOSE	881-005 1.28	1881-005 1.28	881-005P 1.28	25	800	120
3/8X1-1/2	881-015 1.28	1881-015 1.28	881-015P 1.28	25	800	120
3/8X2	881-020 1.64	1881-020 1.64	881-020P 1.64	25	600	120
3/8X2-1/2	881-025 1.64	1881-025 1.64	881-025P 1.64	25	600	120
3/8X3	881-030 1.64	1881-030 1.64	881-030P 1.64	25	400	120
3/8X3-1/2	881-035 2.34	1881-035 2.34	881-035P 2.34	25	400	120
3/8X4	881-040 2.54	1881-040 2.54	881-040P 2.54	25	300	120
3/8X4-1/2	881-045 2.54	1881-045 2.54	881-045P 2.54	25	250	120
3/8X5	881-050 2.74	1881-050 2.74	881-050P 2.74	25	250	120
3/8X5-1/2	881-055 2.74	1881-055 2.74	881-055P 2.74	25	250	120
3/8X6	881-060 2.83	1881-060 2.83	881-060P 2.83	25	250	120
3/8X7	881-070 2.91	1881-070 2.91	881-070P 2.91	25	200	120
3/8X8	881-080 3.13	1881-080 3.13	881-080P 3.13	25	200	120
3/8X9	881-090 3.36	1881-090 3.36	881-090P 3.36	25	200	120
3/8X10	881-100 3.47	1881-100 3.47	881-100P 3.47	25	200	120
3/8X11	881-110 3.67	1881-110 3.67	881-110P 3.67	25	200	120
3/8X12	881-120 3.89	1881-120 3.89	881-120P 3.89	25	200	120
3/8X13	881-130 5.60	1881-130 5.60	881-130P 5.60	25	0	120
3/8X14	881-140 5.80	1881-140 5.80	881-140P 5.80	25	200	120
3/8X15	881-150 6.08	1881-150 6.08	881-150P 6.08	25	200	120
3/8X16	881-160 6.24	1881-160 6.24	881-160P 6.24	25	200	120
3/8X17	881-170 6.46	1881-170 6.46	881-170P 6.46	25	0	120
3/8X18	881-180 6.69	1881-180 6.69	881-180P 6.69	25	200	120
3/8X19	881-190 6.83	1881-190 6.83	881-190P 6.83	25	0	120
3/8X20	881-200 7.02	1881-200 7.02	881-200P 7.02	25	250	120
3/8X22	881-220 7.60	1881-220 7.60	881-220P 7.60	25	0	120
3/8X24	881-240 7.78	1881-240 7.78	881-240P 7.78	25	200	120
3/8X30	881-300 10.49	1881-300 10.49	881-300P 10.49	25	0	120
3/8X36	881-360 13.45	1881-360 13.45	881-360P 13.45	25	0	120
3/8X42	881-420 15.13	1881-420 15.13	881-420P 15.13	25	0	120
3/8X48	881-480 17.13	1881-480 17.13	881-480P 17.13	25	0	120

1/2" Diameter

1/2XCLOSE	882-005 1.11	1882-005 1.11	882-005P 1.11	25	675	120
-----------	-----------------	------------------	------------------	----	-----	-----

PVC Schedule 80 Nipple (continued)

Size	Threaded Both Ends	Threaded One End	Plain End	Std Pk	Mstr Pk	Prod Code
1/2" Diameter						
1/2X1-1/2	882-015 1.11	1882-015 1.11	882-015P 1.11	25	600	120
1/2X2	882-020 1.18	1882-020 1.18	882-020P 1.18	25	150	120
1/2X2-1/2	882-025 1.18	1882-025 1.18	882-025P 1.18	50	600	120
1/2X3	882-030 1.34	1882-030 1.34	882-030P 1.34	25	300	120
1/2X3-1/2	882-035 1.34	1882-035 1.34	882-035P 1.34	25	300	120
1/2X4	882-040 1.56	1882-040 1.56	882-040P 1.56	25	300	120
1/2X4-1/2	882-045 1.56	1882-045 1.56	882-045P 1.56	25	300	120
1/2X5	882-050 1.74	1882-050 1.74	882-050P 1.74	25	300	120
1/2X5-1/2	882-055 1.74	1882-055 1.74	882-055P 1.74	25	300	120
1/2X6	882-060 1.82	1882-060 1.82	882-060P 1.82	25	300	120
1/2X7	882-070 2.12	1882-070 2.12	882-070P 2.12	25	200	120
1/2X8	882-080 2.27	1882-080 2.27	882-080P 2.27	25	0	120
1/2X9	882-090 2.34	1882-090 2.34	882-090P 2.34	25	0	120
1/2X10	882-100 2.48	1882-100 2.48	882-100P 2.48	25	0	120
1/2X11	882-110 2.65	1882-110 2.65	882-110P 2.65	25	0	120
1/2X12	882-120 2.74	1882-120 2.74	882-120P 2.74	25	0	120
1/2X13	882-130 3.13	1882-130 3.13	882-130P 3.13	25	0	120
1/2X14	882-140 3.19	1882-140 3.19	882-140P 3.19	100	0	120
1/2X15	882-150 3.44	1882-150 3.44	882-150P 3.44	100	0	120
1/2X16	882-160 3.84	1882-160 3.84	882-160P 3.84	100	0	120
1/2X17	882-170 3.95	1882-170 3.95	882-170P 3.95	100	0	120
1/2X18	882-180 4.19	1882-180 4.19	882-180P 4.19	25	100	120
1/2X19	882-190 4.33	1882-190 4.33	882-190P 4.33	100	0	120
1/2X20	882-200 4.44	1882-200 4.44	882-200P 4.44	100	0	120
1/2X22	882-220 4.44	1882-220 4.44	882-220P 4.44	100	0	120
1/2X24	882-240 5.42	1882-240 5.42	882-240P 5.42	25	100	120
1/2X30	882-300 6.83	1882-300 6.83	882-300P 6.83	25	0	120
1/2X36	882-360 9.25	1882-360 9.25	882-360P 9.25	25	0	120
1/2X42	882-420 12.34	1882-420 12.34	882-420P 12.34	25	0	120
1/2X48	882-480 12.98	1882-480 12.98	882-480P 12.98	25	0	120

3/4" Diameter

3/4XCLOSE	883-005 1.18	1883-005 1.18	883-005P 1.18	25	450	120
3/4X1-1/2	883-015 1.18	1883-015 1.18	883-015P 1.18	25	500	120
3/4X2	883-020 1.18	1883-020 1.18	883-020P 1.18	25	150	120
3/4X2-1/2	883-025 1.34	1883-025 1.34	883-025P 1.34	25	150	120
3/4X3	883-030 1.34	1883-030 1.34	883-030P 1.34	25	300	120
3/4X3-1/2	883-035 1.56	1883-035 1.56	883-035P 1.56	25	300	120

Nipples PVC, CPVC & PE Nipples



PVC Schedule 80 Nipple

Size	Threaded Both Ends	Threaded One End	Plain End	Std Pk	Mstr Pk	Prod Code
3/4" Diameter						
3/4XCLOSE	883-005 1.18	1883-005 1.18	883-005P 1.18	25	450	120
3/4X1-1/2	883-015 1.18	1883-015 1.18	883-015P 1.18	25	500	120
3/4X2	883-020 1.18	1883-020 1.18	883-020P 1.18	25	150	120
3/4X2-1/2	883-025 1.34	1883-025 1.34	883-025P 1.34	25	150	120
3/4X3	883-030 1.34	1883-030 1.34	883-030P 1.34	25	300	120
3/4X3-1/2	883-035 1.56	1883-035 1.56	883-035P 1.56	25	300	120
3/4X4	883-040 1.82	1883-040 1.82	883-040P 1.82	25	300	120
3/4X4-1/2	883-045 1.82	1883-045 1.82	883-045P 1.82	25	200	120
3/4X5	883-050 2.18	1883-050 2.18	883-050P 2.18	25	200	120
3/4X5-1/2	883-055 2.18	1883-055 2.18	883-055P 2.18	25	200	120
3/4X6	883-060 2.27	1883-060 2.27	883-060P 2.27	25	200	120
3/4X7	883-070 5.30	1883-070 2.34	883-070P 5.30	25	200	120
3/4X8	883-080 2.65	1883-080 2.65	883-080P 5.52	25	0	120
3/4X9	883-090 5.52	1883-090 2.74	883-090P 5.52	25	0	120
3/4X10	883-100 3.04	1883-100 3.04	883-100P 6.18	25	0	120
3/4X11	883-110 6.91	1883-110 3.26	883-110P 6.91	25	0	120
3/4X12	883-120 3.44	1883-120 3.44	883-120P 6.91	25	0	120
3/4X13	883-130 3.72	1883-130 3.72	883-130P 3.72	25	0	120
3/4X14	883-140 3.72	1883-140 3.72	883-140P 3.72	100	0	120
3/4X15	883-150 3.89	1883-150 3.89	883-150P 3.89	100	0	120
3/4X16	883-160 4.33	1883-160 4.33	883-160P 4.33	100	0	120
3/4X17	883-170 4.44	1883-170 4.44	883-170P 4.44	100	0	120
3/4X18	883-180 4.54	1883-180 4.54	883-180P 4.54	25	100	120
3/4X19	883-190 5.07	1883-190 5.07	883-190P 5.07	100	0	120
3/4X20	883-200 5.39	1883-200 5.39	883-200P 5.39	100	0	120
3/4X22	883-220 5.59	1883-220 5.59	883-220P 5.59	100	0	120
3/4X24	883-240 6.52	1883-240 6.52	883-240P 6.52	25	100	120
3/4X30	883-300 9.02	1883-300 9.02	883-300P 9.02	25	0	120
3/4X36	883-360 11.17	1883-360 11.17	883-360P 11.17	25	0	120
3/4X42	883-420 13.06	1883-420 13.06	883-420P 13.06	25	0	120
3/4X48	883-480 14.75	1883-480 14.75	883-480P 14.75	25	0	120
1" Diameter						
1XCLOSE	884-005 1.56	1884-005 1.56	884-005P 1.56	25	300	120
1X1-1/2	884-015 1.74	1884-015 1.74	884-015P 1.74	25	300	120
1X2	884-020 1.74	1884-020 1.74	884-020P 1.74	25	300	120
1X2-1/2	884-025 1.82	1884-025 1.82	884-025P 1.82	25	300	120
1X3	884-030 1.98	1884-030 1.98	884-030P 1.98	25	200	120

PVC Schedule 80 Nipple (continued)

Size	Threaded Both Ends	Threaded One End	Plain End	Std Pk	Mstr Pk	Prod Code
1" Diameter						
1X3-1/2	884-035 2.12	1884-035 2.12	884-035P 2.12	25	200	120
1X4	884-040 2.27	1884-040 2.27	884-040P 2.27	25	200	120
1X4-1/2	884-045 2.48	1884-045 2.48	884-045P 2.48	25	200	120
1X5	884-050 2.74	1884-050 2.74	884-050P 2.74	25	0	120
1X5-1/2	884-055 3.04	1884-055 3.04	884-055P 3.04	25	0	120
1X6	884-060 3.13	1884-060 3.13	884-060P 6.29	25	0	120
1X7	884-070 6.29	1884-070 3.44	884-070P 6.29	25	0	120
1X8	884-080 3.67	1884-080 3.67	884-080P 3.67	25	0	120
1X9	884-090 8.10	1884-090 4.16	884-090P 8.01	25	0	120
1X10	884-100 4.33	1884-100 4.33	884-100P 8.63	25	0	120
1X11	884-110 8.63	1884-110 4.67	884-110P 8.63	25	0	120
1X12	884-120 5.01	1884-120 5.01	884-120P 9.80	25	0	120
1X13	884-130 9.80	1884-130 5.77	884-130P 5.77	25	0	120
1X14	884-140 5.77	1884-140 5.77	884-140P 5.77	50	0	120
1X15	884-150 6.17	1884-150 6.17	884-150P 6.17	50	0	120
1X16	884-160 6.21	1884-160 6.21	884-160P 6.21	50	0	120
1X17	884-170 7.02	1884-170 7.02	884-170P 7.02	50	0	120
1X18	884-180 7.38	1884-180 7.38	884-180P 7.38	50	0	120
1X19	884-190 7.55	1884-190 7.55	884-190P 7.55	50	0	120
1X20	884-200 7.91	1884-200 7.91	884-200P 7.91	50	0	120
1X22	884-220 8.06	1884-220 8.06	884-220P 8.06	50	0	120
1X24	884-240 8.32	1884-240 8.32	884-240P 8.32	50	0	120
1X30	884-300 11.63	1884-300 11.63	884-300P 11.63	15	0	120
1X36	884-360 15.47	1884-360 15.47	884-360P 15.47	15	0	120
1X42	884-420 18.89	1884-420 18.89	884-420P 18.89	15	0	120
1X48	884-480 19.73	1884-480 19.73	884-480P 19.73	15	0	120
1-1/4" Diameter						
1-1/4XCLOSE	885-005 2.27	1885-005 2.27	885-005P 4.38	25	200	120
1-1/4X2	885-020 2.34	1885-020 2.34	885-020P 4.69	25	200	120
1-1/4X2-1/2	885-025 2.56	1885-025 2.56	885-025P 4.69	25	200	120
1-1/4X3	885-030 2.65	1885-030 2.65	885-030P 5.03	25	0	120
1-1/4X3-1/2	885-035 3.04	1885-035 3.04	885-035P 5.03	25	0	120
1-1/4X4	885-040 3.04	1885-040 3.04	885-040P 5.75	25	0	120
1-1/4X4-1/2	885-045 5.75	1885-045 3.47	885-045P 5.75	25	0	120
1-1/4X5	885-050 3.47	1885-050 3.47	885-050P 6.60	25	0	120
1-1/4X5-1/2	885-055 6.60	1885-055 3.89	885-055P 6.60	25	0	120
1-1/4X6	885-060 3.89	1885-060 3.89	885-060P 6.92	25	0	120



Nipples PVC, CPVC & PE Nipples

PVC Schedule 80 Nipple (continued)

Size	Threaded Both Ends	Threaded One End	Plain End	Std Pk	Mstr Pk	Prod Code
1-1/4" Diameter						
1-1/4X3-1/2	885-035 3.04	1885-035 3.04	885-035P 5.03	25	0	120
1-1/4X4	885-040 3.04	1885-040 3.04	885-040P 5.75	25	0	120
1-1/4X4-1/2	885-045 5.75	1885-045 3.47	885-045P 5.75	25	0	120
1-1/4X5	885-050 3.47	1885-050 3.47	885-050P 6.60	25	0	120
1-1/4X5-1/2	885-055 6.60	1885-055 3.89	885-055P 6.60	25	0	120
1-1/4X6	885-060 3.89	1885-060 3.89	885-060P 6.92	25	0	120
1-1/4X7	885-070 4.44	1885-070 4.44	885-070P 4.44	25	0	120
1-1/4X8	885-080 4.67	1885-080 4.67	885-080P 4.67	25	0	120
1-1/4X9	885-090 5.07	1885-090 5.07	885-090P 5.07	25	0	120
1-1/4X10	885-100 5.45	1885-100 5.45	885-100P 5.45	25	0	120
1-1/4X11	885-110 5.83	1885-110 5.83	885-110P 5.83	25	0	120
1-1/4X12	885-120 6.17	1885-120 6.17	885-120P 6.17	25	0	120
1-1/4X13	885-130 7.15	1885-130 7.15	885-130P 7.15	25	0	120
1-1/4X14	885-140 7.41	1885-140 7.41	885-140P 7.41	25	0	120
1-1/4X15	885-150 7.82	1885-150 7.82	885-150P 7.82	25	0	120
1-1/4X16	885-160 8.15	1885-160 8.15	885-160P 8.15	25	0	120
1-1/4X17	885-170 8.93	1885-170 8.93	885-170P 8.93	25	0	120
1-1/4X18	885-180 9.74	1885-180 9.74	885-180P 9.74	25	0	120
1-1/4X19	885-190 10.83	1885-190 10.83	885-190P 10.83	25	0	120
1-1/4X20	885-200 11.05	1885-200 11.05	885-200P 11.05	25	0	120
1-1/4X22	885-220 11.26	1885-220 11.26	885-220P 11.26	25	0	120
1-1/4X24	885-240 11.43	1885-240 11.43	885-240P 11.43	25	0	120
1-1/4X30	885-300 14.92	1885-300 14.92	885-300P 14.92	10	0	120
1-1/4X36	885-360 16.31	1885-360 16.31	885-360P 16.31	10	0	120
1-1/4X42	885-420 20.71	1885-420 20.71	885-420P 20.71	10	0	120
1-1/4X48	885-480 21.55	1885-480 21.55	885-480P 21.55	10	0	120

1-1/2" Diameter

1-1/2XCLOSE	886-005 2.48	1886-005 2.48	886-005P 2.48	25	0	120
1-1/2X2	886-020 2.74	1886-020 2.74	886-020P 2.74	25	0	120
1-1/2X2-1/2	886-025 2.91	1886-025 2.91	886-025P 2.91	25	0	120
1-1/2X3	886-030 3.13	1886-030 3.13	886-030P 3.13	25	0	120
1-1/2X3-1/2	886-035 3.47	1886-035 3.47	886-035P 3.47	25	0	120
1-1/2X4	886-040 4.16	1886-040 4.16	886-040P 4.16	25	0	120
1-1/2X4-1/2	886-045 4.16	1886-045 4.16	886-045P 4.16	25	0	120
1-1/2X5	886-050 4.67	1886-050 4.67	886-050P 4.67	25	0	120
1-1/2X5-1/2	886-055 4.67	1886-055 4.67	886-055P 4.67	25	0	120
1-1/2X6	886-060 5.01	1886-060 5.01	886-060P 8.27	25	0	120

PVC Schedule 80 Nipple (continued)

Size	Threaded Both Ends	Threaded One End	Plain End	Std Pk	Mstr Pk	Prod Code
1-1/2" Diameter						
1-1/2X7	886-070 5.59	1886-070 5.59	886-070P 9.17	25	0	120
1-1/2X8	886-080 6.17	1886-080 6.17	886-080P 6.17	25	0	120
1-1/2X9	886-090 6.54	1886-090 6.54	886-090P 6.54	25	0	120
1-1/2X10	886-100 6.89	1886-100 6.89	886-100P 6.89	25	0	120
1-1/2X11	886-110 7.41	1886-110 7.41	886-110P 7.41	25	0	120
1-1/2X12	886-120 8.32	1886-120 8.32	886-120P 8.32	25	0	120
1-1/2X13	886-130 8.54	1886-130 8.54	886-130P 8.54	25	0	120
1-1/2X14	886-140 9.25	1886-140 9.25	886-140P 9.25	25	0	120
1-1/2X15	886-150 9.65	1886-150 9.65	886-150P 9.65	25	0	120
1-1/2X16	886-160 10.41	1886-160 10.41	886-160P 10.41	25	0	120
1-1/2X17	886-170 10.64	1886-170 10.64	886-170P 10.64	25	0	120
1-1/2X18	886-180 11.33	1886-180 11.33	886-180P 11.33	25	0	120
1-1/2X19	886-190 12.58	1886-190 12.58	886-190P 12.58	25	0	120
1-1/2X20	886-200 12.98	1886-200 12.98	886-200P 12.98	25	0	120
1-1/2X22	886-220 13.13	1886-220 13.13	886-220P 13.13	25	0	120
1-1/2X24	886-240 13.51	1886-240 13.51	886-240P 13.51	25	0	120
1-1/2X30	886-300 18.43	1886-300 18.43	886-300P 18.43	5	0	120
1-1/2X36	886-360 19.34	1886-360 19.34	886-360P 19.34	5	0	120
1-1/2X42	886-420 25.96	1886-420 25.96	886-420P 25.96	5	0	120
1-1/2X48	886-480 27.44	1886-480 27.44	886-480P 27.44	5	0	120

2" Diameter

2XCLOSE	887-005 3.26	1887-005 3.26	887-005P 3.26	25	0	120
2X2	887-020 3.79	1887-020 3.79	887-020P 3.79	25	0	120
2X2-1/2	887-025 3.84	1887-025 3.84	887-025P 3.84	25	0	120
2X3	887-030 3.89	1887-030 3.89	887-030P 3.89	25	0	120
2X3-1/2	887-035 4.54	1887-035 4.54	887-035P 4.54	25	0	120
2X4	887-040 5.39	1887-040 5.39	887-040P 5.39	25	0	120
2X4-1/2	887-045 5.39	1887-045 5.39	887-045P 5.39	25	0	120
2X5	887-050 5.83	1887-050 5.83	887-050P 5.83	25	0	120
2X5-1/2	887-055 5.83	1887-055 5.83	887-055P 5.83	25	0	120
2X6	887-060 7.15	1887-060 7.15	887-060P 7.15	25	0	120
2X7	887-070 7.41	1887-070 7.41	887-070P 7.41	25	0	120
2X8	887-080 7.91	1887-080 7.91	887-080P 7.91	25	0	120
2X9	887-090 8.54	1887-090 8.54	887-090P 8.54	25	0	120
2X10	887-100 9.25	1887-100 9.25	887-100P 9.25	25	0	120
2X11	887-110 9.68	1887-110 9.68	887-110P 9.68	25	0	120
2X12	887-120 10.43	1887-120 10.43	887-120P 10.43	25	0	120

Nipples PVC, CPVC & PE Nipples



PVC Schedule 80 Nipple (continued)

Size	Threaded Both Ends	Threaded One End	Plain End	Std Pk	Mstr Pk	Prod Code
2" Diameter						
2X7	887-070 7.41	1887-070 7.41	887-070P 7.41	25	0	120
2X8	887-080 7.91	1887-080 7.91	887-080P 7.91	25	0	120
2X9	887-090 8.54	1887-090 8.54	887-090P 8.54	25	0	120
2X10	887-100 9.25	1887-100 9.25	887-100P 9.25	25	0	120
2X11	887-110 9.68	1887-110 9.68	887-110P 9.68	25	0	120
2X12	887-120 10.43	1887-120 10.43	887-120P 10.43	25	0	120
2X13	887-130 10.83	1887-130 10.83	887-130P 10.83	25	0	120
2X14	887-140 11.04	1887-140 11.04	887-140P 11.04	20	0	120
2X15	887-150 11.95	1887-150 11.95	887-150P 11.95	20	0	120
2X16	887-160 12.75	1887-160 12.75	887-160P 12.75	20	0	120
2X17	887-170 13.92	1887-170 13.92	887-170P 13.92	20	0	120
2X18	887-180 15.53	1887-180 15.53	887-180P 15.53	20	0	120
2X19	887-190 16.63	1887-190 16.63	887-190P 16.63	25	0	120
2X20	887-200 16.86	1887-200 16.86	887-200P 16.86	20	0	120
2X22	887-220 17.29	1887-220 17.29	887-220P 17.29	20	0	120
2X24	887-240 17.38	1887-240 17.38	887-240P 17.38	20	0	120
2X30	887-300 22.44	1887-300 22.44	887-300P 22.44	5	0	120
2X36	887-360 29.81	1887-360 29.81	887-360P 29.81	5	0	120
2X42	887-420 36.26	1887-420 36.26	887-420P 36.26	5	0	120
2X48	887-480 38.37	1887-480 38.37	887-480P 38.37	5	0	120

2-1/2" Diameter

2-1/2XCLOSE	888-005 11.17	1888-005 11.17	888-005P 11.17	25	0	120
2-1/2X2-1/2	888-025 12.73	1888-025 12.73	888-025P 12.73	25	0	121
2-1/2X3	888-030 12.73	1888-030 12.73	888-030P 12.73	30	0	120
2-1/2X3-1/2	888-035 14.55	1888-035 14.55	888-035P 14.55	25	0	120
2-1/2X4	888-040 16.46	1888-040 16.46	888-040P 16.46	25	0	120
2-1/2X4-1/2	888-045 16.46	1888-045 16.46	888-045P 16.46	25	0	120
2-1/2X5	888-050 18.54	1888-050 18.54	888-050P 18.54	25	0	120
2-1/2X5-1/2	888-055 18.54	1888-055 18.54	888-055P 18.54	25	0	120
2-1/2X6	888-060 20.31	1888-060 20.31	888-060P 20.31	25	0	120
2-1/2X7	888-070 21.40	1888-070 21.40	888-070P 21.40	16	0	120
2-1/2X8	888-080 22.44	1888-080 22.44	888-080P 22.44	16	0	120
2-1/2X9	888-090 25.96	1888-090 25.96	888-090P 25.96	16	0	120
2-1/2X10	888-100 27.51	1888-100 27.51	888-100P 27.51	16	0	120
2-1/2X11	888-110 29.81	1888-110 29.81	888-110P 29.81	16	0	120
2-1/2X12	888-120 30.03	1888-120 30.03	888-120P 30.03	16	0	120
2-1/2X13	888-130 32.40	1888-130 32.40	888-130P 32.40	25	0	120

PVC Schedule 80 Nipple (continued)

Size	Threaded Both Ends	Threaded One End	Plain End	Std Pk	Mstr Pk	Prod Code
2-1/2" Diameter						
2-1/2X14	888-140 33.72	1888-140 33.72	888-140P 33.72	25	0	120
2-1/2X15	888-150 36.26	1888-150 36.26	888-150P 36.26	25	0	120
2-1/2X16	888-160 38.82	1888-160 38.82	888-160P 38.82	20	0	120
2-1/2X17	888-170 39.54	1888-170 39.54	888-170P 39.54	20	0	120
2-1/2X18	888-180 40.21	1888-180 40.21	888-180P 40.21	20	0	120
2-1/2X19	888-190 42.79	1888-190 42.79	888-190P 42.79	25	0	120
2-1/2X20	888-200 44.53	1888-200 44.53	888-200P 44.53	12	0	120
2-1/2X22	888-220 49.48	1888-220 49.48	888-220P 49.48	25	0	120
2-1/2X24	888-240 50.47	1888-240 50.47	888-240P 50.47	10	0	120
2-1/2X30	888-300 61.48	1888-300 61.48	888-300P 61.48	3	0	120
2-1/2X36	888-360 75.14	1888-360 75.14	888-360P 75.14	3	0	120
2-1/2X42	888-420 86.80	1888-420 86.80	888-420P 86.80	3	0	120
2-1/2X48	888-480 93.87	1888-480 93.87	888-480P 93.87	3	0	120

3" Diameter

3XCLOSE	889-005 13.34	1889-005 13.34	889-005P 13.34	25	0	120
3X3	889-030 14.55	1889-030 14.55	889-030P 14.55	20	0	120
3X3-1/2	889-035 17.00	1889-035 17.00	889-035P 17.00	30	0	120
3X4	889-040 19.44	1889-040 19.44	889-040P 19.44	30	0	120
3X4-1/2	889-045 19.44	1889-045 19.44	889-045P 19.44	20	0	120
3X5	889-050 21.79	1889-050 21.79	889-050P 21.79	20	0	120
3X5-1/2	889-055 21.79	1889-055 21.79	889-055P 21.79	20	0	120
3X6	889-060 27.23	1889-060 27.23	889-060P 27.23	20	0	120
3X7	889-070 28.74	1889-070 28.74	889-070P 28.74	10	0	120
3X8	889-080 29.58	1889-080 29.58	889-080P 29.58	10	0	120
3X9	889-090 31.11	1889-090 31.11	889-090P 31.11	10	0	120
3X10	889-100 33.86	1889-100 33.86	889-100P 34.18	10	0	120
3X11	889-110 36.26	1889-110 36.26	889-110P 36.26	10	0	120
3X12	889-120 36.88	1889-120 36.88	889-120P 36.88	10	0	120
3X13	889-130 38.23	1889-130 38.23	889-130P 38.23	20	0	120
3X14	889-140 41.47	1889-140 41.47	889-140P 41.47	20	0	120
3X15	889-150 44.03	1889-150 44.03	889-150P 44.03	20	0	120
3X16	889-160 46.60	1889-160 46.60	889-160P 46.60	20	0	120
3X17	889-170 47.93	1889-170 47.93	889-170P 47.93	10	0	120
3X18	889-180 50.47	1889-180 50.47	889-180P 50.47	10	0	120
3X19	889-190 58.26	1889-190 58.26	889-190P 58.26	10	0	120
3X20	889-200 61.48	1889-200 61.48	889-200P 61.48	10	0	120
3X22	889-220 62.85	1889-220 62.85	889-220P 62.85	10	0	120



Nipples PVC, CPVC & PE Nipples

PVC Schedule 80 Nipple (continued)

Size	Threaded Both Ends	Threaded One End	Plain End	Std Pk	Mstr Pk	Prod Code
3" Diameter						
3X16	889-160 46.60	1889-160 46.60	889-160P 46.60	20	0	120
3X17	889-170 47.93	1889-170 47.93	889-170P 47.93	10	0	120
3X18	889-180 50.47	1889-180 50.47	889-180P 50.47	10	0	120
3X19	889-190 58.26	1889-190 58.26	889-190P 58.26	10	0	120
3X20	889-200 61.48	1889-200 61.48	889-200P 61.48	10	0	120
3X22	889-220 62.85	1889-220 62.85	889-220P 62.85	10	0	120
3X24	889-240 69.26	1889-240 69.26	889-240P 69.26	10	0	120
3X30	889-300 88.21	1889-300 88.21	889-300P 88.21	3	0	120
3X36	889-360 91.24	1889-360 91.24	889-360P 91.24	3	0	120
3X42	889-420 106.82	1889-420 106.82	889-420P 106.82	3	0	120
3X48	889-480 119.14	1889-480 119.14	889-480P 119.14	3	0	120

4" Diameter

4XCLOSE	890-005 21.79	1890-005 21.79	890-005P 21.79	25	0	120
4X2-1/2	890-025 22.85	1890-025 22.85	890-025P 22.85	18	0	120
4X3	890-030 22.85	1890-030 22.85	890-030P 22.85	25	0	120
4X3-1/2	890-035 27.33	1890-035 27.33	890-035P 27.33	25	0	120
4X4	890-040 30.25	1890-040 30.25	890-040P 30.25	18	0	120
4X4-1/2	890-045 30.25	1890-045 30.25	890-045P 30.25	12	0	120
4X5	890-050 30.25	1890-050 30.25	890-050P 30.25	12	0	120
4X5-1/2	890-055 30.25	1890-055 30.25	890-055P 30.25	12	0	120
4X6	890-060 32.40	1890-060 32.40	890-060P 32.40	12	0	120
4X7	890-070 35.56	1890-070 35.56	890-070P 35.56	16	0	120
4X8	890-080 37.61	1890-080 37.61	890-080P 37.61	16	0	120
4X9	890-090 37.85	1890-090 37.85	890-090P 37.85	16	0	120
4X10	890-100 40.21	1890-100 40.21	890-100P 40.21	16	0	120
4X11	890-110 45.38	1890-110 45.38	890-110P 45.38	16	0	120
4X12	890-120 52.39	1890-120 52.39	890-120P 52.39	16	0	120
4X13	890-130 54.36	1890-130 54.36	890-130P 54.36	16	0	120
4X14	890-140 55.69	1890-140 55.69	890-140P 55.69	15	0	120
4X15	890-150 58.26	1890-150 58.26	890-150P 58.26	12	0	120
4X16	890-160 60.89	1890-160 60.89	890-160P 60.89	12	0	120
4X17	890-170 64.77	1890-170 64.77	890-170P 64.77	12	0	120
4X18	890-180 73.05	1890-180 73.05	890-180P 73.05	4	0	120
4X19	890-190 73.78	1890-190 73.78	890-190P 73.78	12	0	120
4X20	890-200 78.99	1890-200 78.99	890-200P 78.99	4	0	120
4X22	890-220 81.56	1890-220 81.56	890-220P 81.56	8	0	120
4X24	890-240 86.95	1890-240 86.95	890-240P 86.95	4	0	120

PVC Schedule 80 Nipple (continued)

Size	Threaded Both Ends	Threaded One End	Plain End	Std Pk	Mstr Pk	Prod Code
4" Diameter						
4X30	890-300 103.59	1890-300 103.59	890-300P 103.59	3	0	120
4X36	890-360 123.04	1890-360 123.04	890-360P 123.04	3	0	120
4X42	890-420 150.20	1890-420 150.20	890-420P 150.20	3	0	120
4X48	890-480 184.38	1890-480 184.38	890-480P 184.38	3	0	120

6" Diameter

6XCLOSE	892-005 23.91	1892-005 23.91	892-005P 23.91	8	0	120
6X4	892-040 30.57	1892-040 30.57	892-040P 30.57	4	0	120
6X4-1/2	892-045 33.88	1892-045 33.88	892-045P 33.88	4	0	120
6X5	892-050 37.19	1892-050 37.19	892-050P 37.19	1	2	120
6X5-1/2	892-055 40.54	1892-055 40.54	892-055P 40.54	1	2	120
6X6	892-060 44.23	1892-060 44.23	892-060P 44.23	1	2	120
6X7	892-070 50.82	1892-070 50.82	892-070P 50.82	1	2	120
6X8	892-080 57.55	1892-080 57.55	892-080P 57.55	1	0	120
6X9	892-090 64.19	1892-090 64.19	892-090P 64.19	1	0	120
6X10	892-100 71.26	1892-100 71.26	892-100P 71.26	1	0	120
6X11	892-110 77.93	1892-110 77.93	892-110P 77.93	1	0	120
6X12	892-120 84.58	1892-120 84.58	892-120P 84.58	1	0	120
6X13	892-130 91.22	1892-130 91.22	892-130P 91.22	1	0	120
6X14	892-140 97.87	1892-140 97.87	892-140P 97.87	1	0	120
6X15	892-150 104.52	1892-150 104.52	892-150P 104.52	1	0	120
6X16	892-160 111.18	1892-160 111.18	892-160P 111.18	1	2	120
6X17	892-170 118.58	1892-170 118.58	892-170P 118.58	1	2	120
6X18	892-180 124.45	1892-180 124.45	892-180P 124.45	1	6	120
6X19	892-190 131.99	1892-190 131.99	892-190P 131.99	1	0	120
6X20	892-200 137.76	1892-200 137.76	892-200P 137.76	2	0	120
6X22	892-220 151.71	1892-220 151.71	892-220P 151.71	1	0	120
6X24	892-240 164.98	1892-240 164.98	892-240P 164.98	1	3	120
6X30	892-300 204.89	1892-300 204.89	892-300P 204.89	1	0	120
6X36	892-360 245.80	1892-360 245.80	892-360P 245.80	1	0	120
6X42	892-420 285.67	1892-420 285.67	892-420P 285.67	1	0	120
6X48	892-480 325.75	1892-480 325.75	892-480P 325.75	1	0	120

8" Diameter

8XCLOSE	893-005 66.13	1893-005 66.13	893-005P 66.13	2	0	120
8X4-1/2	893-045 75.69	1893-045 75.69	893-045P 75.69	1	0	120
8X5	893-050 78.91	1893-050 78.91	893-050P 78.91	1	0	120
8X5-1/2	893-055 82.09	1893-055 82.09	893-055P 82.09	1	0	120
8X6	893-060 85.29	1893-060 85.29	893-060P 85.29	4	0	120

Nipples
PVC, CPVC & PE Nipples



PVC Schedule 80 Nipple

Size	Threaded Both Ends	Threaded One End	Plain End	Std Pk	Mstr Pk	Prod Code
8" Diameter						
8XCLOSE	893-005 66.13	1893-005 66.13	893-005P 66.13	2	0	120
8X4-1/2	893-045 75.69	1893-045 75.69	893-045P 75.69	1	0	120
8X5	893-050 78.91	1893-050 78.91	893-050P 78.91	1	0	120
8X5-1/2	893-055 82.09	1893-055 82.09	893-055P 82.09	1	0	120
8X6	893-060 85.29	1893-060 85.29	893-060P 85.29	4	0	120
8X7	893-070 91.71	1893-070 91.71	893-070P 91.71	4	0	120
8X8	893-080 98.12	1893-080 98.12	893-080P 98.12	4	0	120
8X9	893-090 104.49	1893-090 104.49	893-090P 104.49	2	0	120
8X10	893-100 110.89	1893-100 110.89	893-100P 110.89	1	0	120
8X11	893-110 117.32	1893-110 117.32	893-110P 117.32	1	0	120
8X12	893-120 123.71	1893-120 123.71	893-120P 123.71	1	0	120
8X13	893-130 130.09	1893-130 130.09	893-130P 130.09	1	0	120
8X14	893-140 136.49	1893-140 136.49	893-140P 136.49	1	0	120
8X15	893-150 142.92	1893-150 142.92	893-150P 142.92	1	0	120
8X16	893-160 149.29	1893-160 149.29	893-160P 149.29	1	0	120
8X17	893-170 155.67	1893-170 155.67	893-170P 155.67	4	0	120
8X18	893-180 162.06	1893-180 162.06	893-180P 162.06	4	0	120
8X19	893-190 168.17	1893-190 168.17	893-190P 168.17	2	0	120
8X20	893-200 174.88	1893-200 174.88	893-200P 174.88	2	0	120
8X22	893-220 187.67	1893-220 187.67	893-220P 187.67	1	0	120
8X24	893-240 201.06	1893-240 201.06	893-240P 201.06	1	2	120
8X30	893-300 240.17	1893-300 240.17	893-300P 240.17	4	0	120
8X36	893-360 277.25	1893-360 277.25	893-360P 277.25	4	0	120
8X42	893-420 315.61	1893-420 315.61	893-420P 315.61	1	0	120
8X48	893-480 354.03	1893-480 354.03	893-480P 354.03	1	0	120
10" Diameter						
10XCLOSE	894-005 75.89	1894-005 75.89	894-005P 75.89	1	0	120
10X2	894-020 76.74	1894-020 76.74	894-020P 76.74	1	6	120
10X4-1/2	894-045 90.39	1894-045 90.39	894-045P 90.39	1	0	120
10X5	894-050 94.81	1894-050 94.81	894-050P 94.81	1	0	120
10X5-1/2	894-055 100.04	1894-055 100.04	894-055P 100.04	1	0	120
10X6	894-060 104.87	1894-060 104.87	894-060P 104.87	2	0	120
10X7	894-070 114.53	1894-070 114.53	894-070P 114.53	1	0	120
10X8	894-080 124.18	1894-080 124.18	894-080P 124.18	1	0	120
10X9	894-090 133.66	1894-090 133.66	894-090P 133.66	1	0	120
10X10	894-100 143.52	1894-100 143.52	894-100P 143.52	1	0	120
10X11	894-110 153.17	1894-110 153.17	894-110P 153.17	1	0	120

PVC Schedule 80 Nipple (continued)

Size	Threaded Both Ends	Threaded One End	Plain End	Std Pk	Mstr Pk	Prod Code
10" Diameter						
10X12	894-120 162.83	1894-120 162.83	894-120P 162.83	1	0	120
10X13	894-130 172.47	1894-130 172.47	894-130P 172.47	1	0	120
10X14	894-140 182.15	1894-140 182.15	894-140P 182.15	1	0	120
10X15	894-150 191.80	1894-150 191.80	894-150P 191.80	1	0	120
10X16	894-160 201.45	1894-160 201.45	894-160P 201.45	1	0	120
10X17	894-170 211.12	1894-170 211.12	894-170P 211.12	1	0	120
10X18	894-180 220.78	1894-180 220.78	894-180P 220.78	1	2	120
10X19	894-190 230.42	1894-190 230.42	894-190P 230.42	1	0	120
10X20	894-200 240.09	1894-200 240.09	894-200P 240.09	1	0	120
10X22	894-220 260.21	1894-220 260.21	894-220P 260.21	1	0	120
10X24	894-240 278.74	1894-240 278.74	894-240P 278.74	1	2	120
10X30	894-300 336.68	1894-300 336.68	894-300P 336.68	1	0	120
10X36	894-360 394.63	1894-360 394.63	894-360P 394.63	1	0	120
10X42	894-420 452.59	1894-420 452.59	894-420P 452.59	1	0	120
10X48	894-480 510.56	1894-480 510.56	894-480P 510.56	1	0	120
12" Diameter						
12XCLOSE	895-005 92.13	1895-005 92.13	895-005P 92.13	1	0	120
12X5	895-050 113.31	1895-050 113.31	895-050P 113.31	1	0	120
12X5-1/2	895-055 119.96	1895-055 119.96	895-055P 119.96	1	0	120
12X6	895-060 126.59	1895-060 126.61	895-060P 126.59	1	0	120
12X7	895-070 139.85	1895-070 139.85	895-070P 139.85	1	0	120
12X8	895-080 152.67	1895-080 152.67	895-080P 152.67	1	0	120
12X9	895-090 166.43	1895-090 166.43	895-090P 166.43	1	0	120
12X10	895-100 179.69	1895-100 179.69	895-100P 179.69	1	0	120
12X11	895-110 192.99	1895-110 192.99	895-110P 192.99	1	0	120
12X12	895-120 206.25	1895-120 206.25	895-120P 206.25	1	0	120
12X13	895-130 219.54	1895-130 219.54	895-130P 219.54	1	0	120
12X14	895-140 232.82	1895-140 232.82	895-140P 232.82	1	0	120
12X15	895-150 246.12	1895-150 246.12	895-150P 246.12	1	0	120
12X16	895-160 259.38	1895-160 259.38	895-160P 259.38	1	0	120
12X17	895-170 272.65	1895-170 272.65	895-170P 272.65	1	0	120
12X18	895-180 285.93	1895-180 285.93	895-180P 285.93	1	0	120
12X19	895-190 299.20	1895-190 299.20	895-190P 299.20	1	0	120
12X20	895-200 312.47	1895-200 312.47	895-200P 312.47	1	0	120
12X22	895-220 339.05	1895-220 339.05	895-220P 339.05	1	0	120
12X24	895-240 365.61	1895-240 365.61	895-240P 365.61	1	0	120
12X30	895-300 445.27	1895-300 445.27	895-300P 445.27	1	0	120



Nipples PVC, CPVC & PE Nipples

PVC Nipples

PVC Schedule 80 Nipple (continued)

Size	Threaded Both Ends	Threaded One End	Plain End	Std Pk	Mstr Pk	Prod Code
12" Diameter						
12X18	895-180	1895-180	895-180P	1	0	120
	285.93	285.93	285.93			
12X19	895-190	1895-190	895-190P	1	0	120
	299.20	299.20	299.20			
12X20	895-200	1895-200	895-200P	1	0	120
	312.47	312.47	312.47			
12X22	895-220	1895-220	895-220P	1	0	120
	339.05	339.05	339.05			
12X24	895-240	1895-240	895-240P	1	0	120
	365.61	365.61	365.61			

PVC Schedule 80 Nipple (continued)

Size	Threaded Both Ends	Threaded One End	Plain End	Std Pk	Mstr Pk	Prod Code
12" Diameter						
12X30	895-300	1895-300	895-300P	1	0	120
	445.27	445.27	445.27			
12X36	895-360	1895-360	895-360P	1	0	120
	524.96	524.96	524.96			
12X42	895-420	1895-420	895-420P	1	0	120
	631.17	631.17	631.17			
12X48	895-480	1895-480	895-480P	1	0	120
	684.27	684.27	684.27			

Machined PVC Nipple Options - Threaded Both Ends (TBE)

The following nipples are normally injection molded, but are optionally available as machined nipples listed below. All other nipples are normally machined.

Part Number	Size	Std Pk	Mstr Ctn	Prod Code	Price Each
-------------	------	--------	----------	-----------	------------

PVC Schedule 80 Machined Nipples

1/4" Diameter

880-005M	1/4XCLOSE	25	1200	120	4.06
880-015M	1/4X1-1/2	25	1200	120	4.32
880-020M	1/4X2	25	500	120	2.96
880-030M	1/4X3	25	500	120	2.01
880-040M	1/4X4	25	250	120	5.13
880-050M	1/4X5	25	250	120	5.39

PVC Schedule 80 Machined Nipples

3/8" Diameter

881-015M	3/8X1-1/2	25	800	120	4.63
881-020M	3/8X2	25	600	120	4.63
881-030M	3/8X3	25	400	120	4.63
881-040M	3/8X4	25	300	120	5.86

PVC Schedule 80 Machined Nipples

1/2" Diameter

882-005M	1/2XCLOSE	25	450	120	3.42
882-015M	1/2X1-1/2	25	600	120	3.43
882-020M	1/2X2	25	300	120	3.43
882-025M	1/2X2-1/2	25	300	120	3.43
882-030M	1/2X3	25	300	120	3.55
882-040M	1/2X4	25	300	120	3.73
882-045M	1/2X4-1/2	25	300	120	3.99
882-050M	1/2X5	25	300	120	4.16
882-060M	1/2X6	25	300	120	4.34
882-070M	1/2X7	25	200	120	4.59
882-080M	1/2X8	25	0	120	4.94
882-100M	1/2X10	25	0	120	5.47
882-120M	1/2X12	25	0	120	6.00

PVC Schedule 80 Machined Nipples

3/4" Diameter

883-005M	3/4XCLOSE	25	300	120	3.74
883-015M	3/4X1-1/2	25	300	120	3.74

PVC Schedule 80 Machined Nipples (continued)

3/4" Diameter

883-020M	3/4X2	25	300	120	4.01
883-025M	3/4X2-1/2	25	300	120	4.06
883-030M	3/4X3	25	300	120	4.09
883-035M	3/4X3-1/2	25	300	120	4.15
883-040M	3/4X4	25	300	120	4.44
883-045M	3/4X4-1/2	25	200	120	4.52
883-050M	3/4X5	25	200	120	4.84
883-060M	3/4X6	25	200	120	5.19
883-080M	3/4X8	25	0	120	5.52
883-100M	3/4X10	25	0	120	6.18
883-120M	3/4X12	25	0	120	6.91

PVC Schedule 80 Machined Nipples

1" Diameter

884-005M	1XCLOSE	25	300	120	4.30
884-020M	1X2	25	300	120	4.60
884-025M	1X2-1/2	25	200	120	4.56
884-030M	1X3	25	200	120	4.64
884-040M	1X4	25	200	120	5.18
884-050M	1X5	25	0	120	5.75
884-060M	1X6	25	0	120	6.29
884-080M	1X8	25	0	120	7.40
884-100M	1X10	25	0	120	8.63
884-120M	1X12	25	0	120	9.80

PVC Schedule 80 Machined Nipples

1-1/4" Diameter

885-005M	1-1/4XCLOSE	25	200	120	4.38
885-020M	1-1/4X2	25	200	120	4.69
885-030M	1-1/4X3	25	0	120	5.03
885-040M	1-1/4X4	25	0	120	5.75
885-060M	1-1/4X6	25	0	120	6.92
885-120M	1-1/4X12	25	0	120	10.93

PVC Schedule 80 Machined Nipples

1-1/2" Diameter

886-005M	1-1/2XCLOSE	25	0	120	4.97
886-020M	1-1/2X2	25	0	120	5.32
886-030M	1-1/2X3	25	0	120	3.13

Nipples
PVC, CPVC & PE Nipples



Machined PVC Nipple Options - Threaded Both Ends (TBE)

Part Number	Size	Std Pk	Mstr Ctn	Prod Code	Price Each
-------------	------	--------	----------	-----------	------------

Part Number	Size	Std Pk	Mstr Ctn	Prod Code	Price Each
-------------	------	--------	----------	-----------	------------

PVC Schedule 80 Machined Nipples (continued)

1-1/2" Diameter

886-040M	1-1/2X4	25	0	120	6.63
886-060M	1-1/2X6	25	0	120	8.27
886-070M	1-1/2X7	25	0	120	9.17
886-080M	1-1/2X8	25	0	120	10.02
886-100M	1-1/2X10	25	0	120	11.76
886-120M	1-1/2X12	25	0	120	13.48

PVC Schedule 80 Machined Nipples

2" Diameter

887-005M	2XCLOSE	25	0	120	5.93
887-030M	2X3	25	0	120	7.21
887-040M	2X4	25	0	120	8.34
887-060M	2X6	25	0	120	10.79

PVC Reducing Nipples

PVC Reducing Nipples

Part Number	Size	Std Pk	Mstr Ctn	Prod Code	Price Each
882-101	3/4X1/2	50	300	120	1.55
884-130R	1X1/2	25	300	120	2.09
884-131	1X3/4	50	200	120	2.17

CPVC Nipples

CPVC Schedule 80 Nipple

Size	Threaded Both Ends	Threaded One End	Plain End	Std Pk	Mstr Pk	Prod Code
1/4" Diameter						
1/4XCLOSE	880-005C 2.54	1880-005C 2.54	880-005CP 2.54	25	1200	121
1/4X1-1/2	880-015C 2.74	1880-015C 2.74	880-015CP 2.74	25	1200	121
1/4X2	880-020C 2.96	1880-020C 2.96	880-020CP 2.96	25	500	121
1/4X2-1/2	880-025C 3.44	1880-025C 3.44	880-025CP 3.44	25	500	121
1/4X3	880-030C 3.44	1880-030C 3.44	880-030CP 3.44	25	500	121
1/4X3-1/2	880-035C 3.89	1880-035C 3.89	880-035CP 3.89	25	500	121
1/4X4	880-040C 3.89	1880-040C 3.89	880-040CP 3.89	25	250	121
1/4X4-1/2	880-045C 4.36	1880-045C 4.36	880-045CP 4.36	25	250	121
1/4X5	880-050C 4.36	1880-050C 4.36	880-050CP 4.36	25	250	121
1/4X5-1/2	880-055C 4.74	1880-055C 4.74	880-055CP 4.74	25	250	121
1/4X6	880-060C 4.74	1880-060C 4.74	880-060CP 4.74	25	250	121
1/4X7	880-070C 7.17	1880-070C 7.17	880-070CP 7.17	25	250	121
1/4X8	880-080C 7.71	1880-080C 7.71	880-080CP 7.71	25	250	121
1/4X9	880-090C 8.19	1880-090C 8.19	880-090CP 8.19	25	250	121
1/4X10	880-100C 8.62	1880-100C 8.62	880-100CP 8.62	25	250	121
1/4X11	880-110C 9.14	1880-110C 9.14	880-110CP 9.14	25	250	121
1/4X12	880-120C 9.53	1880-120C 9.53	880-120CP 9.53	25	250	121
1/4X13	880-130C 12.07	1880-130C 12.07	880-130CP 12.07	25	250	121
1/4X14	880-140C 15.51	1880-140C 15.51	880-140CP 15.51	25	250	121
1/4X15	880-150C 16.13	1880-150C 16.13	880-150CP 16.13	25	500	121
1/4X16	880-160C 16.33	1880-160C 16.33	880-160CP 16.33	25	250	121
1/4X17	880-170C 17.19	1880-170C 17.19	880-170CP 17.19	25	0	121

CPVC Schedule 80 Nipple (continued)

Size	Threaded Both Ends	Threaded One End	Plain End	Std Pk	Mstr Pk	Prod Code
1/4" Diameter						
1/4X18	880-180C 18.59	1880-180C 18.59	880-180CP 18.59	25	300	121
1/4X19	880-190C 18.97	1880-190C 18.97	880-190CP 18.97	25	0	121
1/4X20	880-200C 19.47	1880-200C 19.47	880-200CP 19.47	25	0	121
1/4X22	880-220C 20.18	1880-220C 20.18	880-220CP 20.18	25	300	121
1/4X24	880-240C 23.33	1880-240C 23.33	880-240CP 23.33	25	0	121
1/4X30	880-300C 28.24	1880-300C 28.24	880-300CP 28.24	25	0	121
1/4X36	880-360C 33.34	1880-360C 33.34	880-360CP 33.34	25	0	121
1/4X42	880-420C 39.12	1880-420C 39.12	880-420CP 39.12	25	0	121
1/4X48	880-480C 40.85	1880-480C 40.85	880-480CP 40.85	25	0	121
3/8" Diameter						
3/8XCLOSE	881-005C 2.91	1881-005C 2.91	881-005CP 2.91	25	800	121
3/8X1-1/2	881-015C 3.04	1881-015C 3.04	881-015CP 3.04	25	800	121
3/8X2	881-020C 3.44	1881-020C 3.44	881-020CP 3.44	25	600	121
3/8X2-1/2	881-025C 3.88	1881-025C 3.88	881-025CP 3.88	25	600	121
3/8X3	881-030C 4.07	1881-030C 4.07	881-030CP 4.07	25	400	121
3/8X3-1/2	881-035C 4.54	1881-035C 4.54	881-035CP 4.54	25	400	121
3/8X4	881-040C 4.92	1881-040C 4.92	881-040CP 4.92	25	300	121
3/8X4-1/2	881-045C 5.39	1881-045C 5.39	881-045CP 5.39	25	250	121
3/8X5	881-050C 5.80	1881-050C 5.80	881-050CP 5.80	25	250	121
3/8X5-1/2	881-055C 6.37	1881-055C 6.37	881-055CP 6.37	25	250	121
3/8X6	881-060C 7.05	1881-060C 7.05	881-060CP 7.05	25	250	121
3/8X7	881-070C 8.46	1881-070C 8.46	881-070CP 8.46	25	200	121

Made in the U.S.A.

Suitable for Oil-Free air handling to 25 psi, not for distribution of compressed air or gas
Due to Material Cost Variations, Prices Subject to Change. Check On-line Catalog @ www.spearsmfg.com



Nipples PVC, CPVC & PE Nipples

CPVC Schedule 80 Nipple (continued)

Size	Threaded Both Ends	Threaded One End	Plain End	Std Pk	Mstr Pk	Prod Code
3/8" Diameter						
3/8X5	881-050C 5.80	1881-050C 5.80	881-050CP 5.80	25	250	121
3/8X5-1/2	881-055C 6.37	1881-055C 6.37	881-055CP 6.37	25	250	121
3/8X6	881-060C 7.05	1881-060C 7.05	881-060CP 7.05	25	250	121
3/8X7	881-070C 8.46	1881-070C 8.46	881-070CP 8.46	25	200	121
3/8X8	881-080C 8.85	1881-080C 8.85	881-080CP 8.85	25	200	121
3/8X9	881-090C 9.86	1881-090C 9.86	881-090CP 9.86	25	200	121
3/8X10	881-100C 10.04	1881-100C 10.04	881-100CP 10.04	25	200	121
3/8X11	881-110C 10.67	1881-110C 10.67	881-110CP 10.67	25	200	121
3/8X12	881-120C 10.87	1881-120C 10.87	881-120CP 10.87	25	200	121
3/8X13	881-130C 13.94	1881-130C 13.94	881-130CP 13.94	25	0	121
3/8X14	881-140C 16.97	1881-140C 16.97	881-140CP 16.97	25	200	121
3/8X15	881-150C 17.35	1881-150C 17.35	881-150CP 17.35	25	200	121
3/8X16	881-160C 17.76	1881-160C 17.76	881-160CP 17.76	25	200	121
3/8X17	881-170C 18.38	1881-170C 18.38	881-170CP 18.38	25	0	121
3/8X18	881-180C 19.01	1881-180C 19.01	881-180CP 19.01	25	200	121
3/8X19	881-190C 19.60	1881-190C 19.60	881-190CP 19.60	25	0	121
3/8X20	881-200C 20.22	1881-200C 20.22	881-200CP 20.22	25	0	121
3/8X22	881-220C 20.87	1881-220C 20.87	881-220CP 20.87	25	0	121
3/8X24	881-240C 21.82	1881-240C 21.82	881-240CP 21.82	25	0	121
3/8X30	881-300C 33.37	1881-300C 33.37	881-300CP 33.37	25	0	121
3/8X36	881-360C 41.21	1881-360C 41.21	881-360CP 41.21	25	0	121
3/8X42	881-420C 42.19	1881-420C 42.19	881-420CP 42.19	25	0	121
3/8X48	881-480C 43.65	1881-480C 43.65	881-480CP 43.65	25	0	121

1/2" Diameter

1/2XCLOSE	882-005C 2.74	1882-005C 2.74	882-005CP 2.74	25	450	121
1/2X1-1/2	882-015C 2.96	1882-015C 2.96	882-015CP 2.96	25	600	121
1/2X2	882-020C 3.26	1882-020C 3.26	882-020CP 3.26	25	300	121
1/2X2-1/2	882-025C 3.47	1882-025C 3.47	882-025CP 3.47	25	300	121
1/2X3	882-030C 3.72	1882-030C 3.72	882-030CP 3.72	25	300	121
1/2X3-1/2	882-035C 4.36	1882-035C 4.36	882-035CP 4.36	25	300	121
1/2X4	882-040C 4.36	1882-040C 4.36	882-040CP 4.36	25	300	121
1/2X4-1/2	882-045C 4.89	1882-045C 4.89	882-045CP 4.89	25	300	121
1/2X5	882-050C 4.89	1882-050C 4.89	882-050CP 4.89	25	300	121
1/2X5-1/2	882-055C 5.52	1882-055C 5.52	882-055CP 5.52	25	300	121
1/2X6	882-060C 5.52	1882-060C 5.52	882-060CP 5.52	25	300	121
1/2X7	882-070C 8.06	1882-070C 8.06	882-070CP 8.06	25	200	121
1/2X8	882-080C 8.60	1882-080C 8.60	882-080CP 8.60	25	0	121

CPVC Schedule 80 Nipple (continued)

Size	Threaded Both Ends	Threaded One End	Plain End	Std Pk	Mstr Pk	Prod Code
1/2" Diameter						
1/2X9	882-090C 9.28	1882-090C 9.28	882-090CP 9.28	25	0	121
1/2X10	882-100C 9.77	1882-100C 9.77	882-100CP 9.77	25	0	121
1/2X11	882-110C 10.41	1882-110C 10.41	882-110CP 10.41	25	0	121
1/2X12	882-120C 11.04	1882-120C 11.04	882-120CP 11.04	25	0	121
1/2X13	882-130C 13.61	1882-130C 13.61	882-130CP 13.61	25	0	121
1/2X14	882-140C 16.17	1882-140C 16.17	882-140CP 16.17	100	0	121
1/2X15	882-150C 16.67	1882-150C 16.67	882-150CP 16.67	100	0	121
1/2X16	882-160C 17.22	1882-160C 17.22	882-160CP 17.22	100	0	121
1/2X17	882-170C 17.96	1882-170C 17.96	882-170CP 17.96	100	0	121
1/2X18	882-180C 18.26	1882-180C 18.26	882-180CP 18.26	25	100	121
1/2X19	882-190C 18.93	1882-190C 18.93	882-190CP 18.93	100	0	121
1/2X20	882-200C 19.57	1882-200C 19.57	882-200CP 19.57	100	0	121
1/2X22	882-220C 21.07	1882-220C 21.07	882-220CP 21.07	100	0	121
1/2X24	882-240C 22.13	1882-240C 22.13	882-240CP 22.13	100	0	121
1/2X30	882-300C 33.23	1882-300C 33.23	882-300CP 33.23	25	0	121
1/2X36	882-360C 36.56	1882-360C 36.56	882-360CP 36.56	25	0	121
1/2X42	882-420C 40.05	1882-420C 40.05	882-420CP 40.05	25	0	121
1/2X48	882-480C 44.18	1882-480C 44.18	882-480CP 44.18	25	0	121

3/4" Diameter

3/4XCLOSE	883-005C 3.36	1883-005C 3.36	883-005CP 3.36	25	300	121
3/4X1-1/2	883-015C 3.61	1883-015C 3.61	883-015CP 3.61	25	300	121
3/4X2	883-020C 3.89	1883-020C 3.89	883-020CP 3.89	25	300	121
3/4X2-1/2	883-025C 4.44	1883-025C 4.44	883-025CP 4.44	25	300	121
3/4X3	883-030C 4.44	1883-030C 4.44	883-030CP 4.44	25	300	121
3/4X3-1/2	883-035C 5.14	1883-035C 5.14	883-035CP 5.14	25	300	121
3/4X4	883-040C 5.14	1883-040C 5.14	883-040CP 5.14	25	300	121
3/4X4-1/2	883-045C 5.69	1883-045C 5.69	883-045CP 5.69	25	200	121
3/4X5	883-050C 5.69	1883-050C 5.69	883-050CP 5.69	25	200	121
3/4X5-1/2	883-055C 6.36	1883-055C 6.36	883-055CP 6.36	25	200	121
3/4X6	883-060C 6.36	1883-060C 6.36	883-060CP 6.36	25	200	121
3/4X7	883-070C 9.57	1883-070C 9.57	883-070CP 9.57	25	200	121
3/4X8	883-080C 10.11	1883-080C 10.11	883-080CP 10.11	25	0	121
3/4X9	883-090C 10.83	1883-090C 10.83	883-090CP 10.83	25	0	121
3/4X10	883-100C 11.36	1883-100C 11.36	883-100CP 11.36	25	0	121
3/4X11	883-110C 12.06	1883-110C 12.06	883-110CP 12.06	25	0	121
3/4X12	883-120C 12.78	1883-120C 12.78	883-120CP 12.78	25	0	121
3/4X13	883-130C 15.97	1883-130C 15.97	883-130CP 15.97	25	0	121

Nipples PVC, CPVC & PE Nipples



CPVC Schedule 80 Nipple (continued)

Size	Threaded Both Ends	Threaded One End	Plain End	Std Pk	Mstr Pk	Prod Code
3/4" Diameter						
3/4X8	883-080C 10.11	1883-080C 10.11	883-080CP 10.11	25	0	121
3/4X9	883-090C 10.83	1883-090C 10.83	883-090CP 10.83	25	0	121
3/4X10	883-100C 11.36	1883-100C 11.36	883-100CP 11.36	25	0	121
3/4X11	883-110C 12.06	1883-110C 12.06	883-110CP 12.06	25	0	121
3/4X12	883-120C 12.78	1883-120C 12.78	883-120CP 12.78	25	0	121
3/4X13	883-130C 15.97	1883-130C 15.97	883-130CP 15.97	25	0	121
3/4X14	883-140C 19.15	1883-140C 19.15	883-140CP 19.15	100	0	121
3/4X15	883-150C 19.67	1883-150C 19.67	883-150CP 19.67	100	0	121
3/4X16	883-160C 20.25	1883-160C 20.25	883-160CP 20.25	100	0	121
3/4X17	883-170C 20.92	1883-170C 20.92	883-170CP 20.92	100	0	121
3/4X18	883-180C 21.60	1883-180C 21.60	883-180CP 21.60	100	0	121
3/4X19	883-190C 22.17	1883-190C 22.17	883-190CP 22.17	100	0	121
3/4X20	883-200C 22.75	1883-200C 22.75	883-200CP 22.75	100	0	121
3/4X22	883-220C 24.14	1883-220C 24.14	883-220CP 24.14	100	0	121
3/4X24	883-240C 25.55	1883-240C 25.55	883-240CP 25.55	100	0	121
3/4X30	883-300C 38.96	1883-300C 38.96	883-300CP 38.96	25	0	121
3/4X36	883-360C 42.47	1883-360C 42.47	883-360CP 42.37	25	0	121
3/4X42	883-420C 46.63	1883-420C 46.63	883-420CP 46.63	25	0	121
3/4X48	883-480C 49.72	1883-480C 49.72	883-480CP 49.72	25	0	121
1" Diameter						
1XCLOSE	884-005C 4.07	1884-005C 4.07	884-005CP 4.07	25	300	121
1X2	884-020C 4.44	1884-020C 4.44	884-020CP 4.44	25	300	121
1X2-1/2	884-025C 5.52	1884-025C 5.52	884-025CP 5.52	25	200	121
1X3	884-030C 5.52	1884-030C 5.52	884-030CP 5.52	25	200	121
1X3-1/2	884-035C 6.36	1884-035C 6.36	884-035CP 6.36	25	200	121
1X4	884-040C 6.36	1884-040C 6.36	884-040CP 6.36	25	200	121
1X4-1/2	884-045C 7.17	1884-045C 7.17	884-045CP 7.17	25	200	121
1X5	884-050C 7.17	1884-050C 7.17	884-050CP 7.17	25	0	121
1X5-1/2	884-055C 8.32	1884-055C 8.32	884-055CP 8.32	25	0	121
1X6	884-060C 8.32	1884-060C 8.32	884-060CP 8.32	25	0	121
1X7	884-070C 11.63	1884-070C 11.63	884-070CP 11.63	25	0	121
1X8	884-080C 12.74	1884-080C 12.74	884-080CP 12.74	25	0	121
1X9	884-090C 13.82	1884-090C 13.82	884-090CP 13.82	25	0	121
1X10	884-100C 14.84	1884-100C 14.84	884-100CP 14.84	25	0	121
1X11	884-110C 15.52	1884-110C 15.52	884-110CP 15.52	25	0	121
1X12	884-120C 16.68	1884-120C 16.68	884-120CP 16.68	25	0	121
1X13	884-130C 19.95	1884-130C 19.95	884-130CP 19.95	25	0	121

CPVC Schedule 80 Nipple (continued)

Size	Threaded Both Ends	Threaded One End	Plain End	Std Pk	Mstr Pk	Prod Code
1" Diameter						
1X14	884-140C 23.26	1884-140C 23.26	884-140CP 23.26	50	0	121
1X15	884-150C 24.38	1884-150C 24.38	884-150CP 24.38	50	0	121
1X16	884-160C 25.52	1884-160C 25.52	884-160CP 25.52	50	0	121
1X17	884-170C 26.59	1884-170C 26.59	884-170CP 26.59	50	0	121
1X18	884-180C 27.67	1884-180C 27.67	884-180CP 27.67	50	0	121
1X19	884-190C 28.26	1884-190C 28.26	884-190CP 28.26	50	0	121
1X20	884-200C 28.94	1884-200C 28.94	884-200CP 28.94	50	0	121
1X22	884-220C 31.41	1884-220C 31.41	884-220CP 31.41	50	0	121
1X24	884-240C 33.26	1884-240C 33.26	884-240CP 33.26	50	0	121
1X30	884-300C 48.81	1884-300C 48.81	884-300CP 48.81	15	0	121
1X36	884-360C 55.32	1884-360C 55.32	884-360CP 55.32	15	0	121
1X42	884-420C 58.63	1884-420C 58.63	884-420CP 58.63	15	0	121
1X48	884-480C 66.57	1884-480C 66.57	884-480CP 66.57	15	0	121
1-1/4" Diameter						
1-1/4XCLOSE	885-005C 5.14	1885-005C 5.14	885-005CP 5.14	25	200	121
1-1/4X2	885-020C 5.69	1885-020C 5.69	885-020CP 5.69	25	200	121
1-1/4X2-1/2	885-025C 7.17	1885-025C 7.17	885-025CP 7.17	25	200	121
1-1/4X3	885-030C 7.58	1885-030C 7.58	885-030CP 7.58	25	0	121
1-1/4X3-1/2	885-035C 8.93	1885-035C 8.93	885-035CP 8.93	25	0	121
1-1/4X4	885-040C 8.93	1885-040C 8.93	885-040CP 8.93	25	0	121
1-1/4X4-1/2	885-045C 10.49	1885-045C 10.49	885-045CP 10.49	25	0	121
1-1/4X5	885-050C 10.49	1885-050C 10.49	885-050CP 10.49	25	0	121
1-1/4X5-1/2	885-055C 12.06	1885-055C 12.06	885-055CP 12.06	25	0	121
1-1/4X6	885-060C 12.06	1885-060C 12.06	885-060CP 12.06	25	0	121
1-1/4X7	885-070C 17.71	1885-070C 17.71	885-070CP 17.71	25	0	121
1-1/4X8	885-080C 18.43	1885-080C 18.43	885-080CP 18.43	25	0	121
1-1/4X9	885-090C 19.25	1885-090C 19.25	885-090CP 19.25	25	0	121
1-1/4X10	885-100C 20.95	1885-100C 20.95	885-100CP 20.95	25	0	121
1-1/4X11	885-110C 22.54	1885-110C 22.54	885-110CP 22.54	25	0	121
1-1/4X12	885-120C 24.08	1885-120C 24.08	885-120CP 24.08	25	0	121
1-1/4X13	885-130C 28.22	1885-130C 28.22	885-130CP 28.22	25	0	121
1-1/4X14	885-140C 32.35	1885-140C 32.35	885-140CP 32.35	25	0	121
1-1/4X15	885-150C 33.88	1885-150C 33.88	885-150CP 33.88	25	0	121
1-1/4X16	885-160C 35.42	1885-160C 35.42	885-160CP 35.42	25	0	121
1-1/4X17	885-170C 37.00	1885-170C 37.00	885-170CP 37.00	25	0	121
1-1/4X18	885-180C 39.32	1885-180C 39.32	885-180CP 39.32	25	0	121
1-1/4X19	885-190C 40.25	1885-190C 40.25	885-190CP 40.25	25	0	121



Nipples PVC, CPVC & PE Nipples

CPVC Schedule 80 Nipple (continued)

Size	Threaded Both Ends	Threaded One End	Plain End	Std Pk	Mstr Pk	Prod Code
1-1/4" Diameter						
1-1/4X14	885-140C 32.35	1885-140C 32.35	885-140CP 32.35	25	0	121
1-1/4X15	885-150C 33.88	1885-150C 33.88	885-150CP 33.88	25	0	121
1-1/4X16	885-160C 35.42	1885-160C 35.42	885-160CP 35.42	25	0	121
1-1/4X17	885-170C 37.00	1885-170C 37.00	885-170CP 37.00	25	0	121
1-1/4X18	885-180C 39.32	1885-180C 39.32	885-180CP 39.32	25	0	121
1-1/4X19	885-190C 40.25	1885-190C 40.25	885-190CP 40.25	25	0	121
1-1/4X20	885-200C 41.93	1885-200C 41.93	885-200CP 41.93	25	0	121
1-1/4X22	885-220C 45.04	1885-220C 45.04	885-220CP 45.04	25	0	121
1-1/4X24	885-240C 51.47	1885-240C 51.47	885-240CP 51.47	25	0	121
1-1/4X30	885-300C 67.77	1885-300C 67.77	885-300CP 67.77	10	0	121
1-1/4X36	885-360C 71.54	1885-360C 71.54	885-360CP 71.54	10	0	121
1-1/4X42	885-420C 86.74	1885-420C 86.74	885-420CP 86.74	10	0	121
1-1/4X48	885-480C 96.33	1885-480C 96.33	885-480CP 96.33	10	0	121

1-1/2" Diameter

1-1/2XCLOSE	886-005C 5.69	1886-005C 5.69	886-005CP 5.69	25	0	121
1-1/2X2	886-020C 6.36	1886-020C 6.36	886-020CP 6.36	25	0	121
1-1/2X2-1/2	886-025C 7.91	1886-025C 7.91	886-025CP 7.91	25	0	121
1-1/2X3	886-030C 7.91	1886-030C 7.91	886-030CP 7.91	25	0	121
1-1/2X3-1/2	886-035C 9.57	1886-035C 9.57	886-035CP 9.57	25	0	121
1-1/2X4	886-040C 9.57	1886-040C 9.57	886-040CP 9.57	25	0	121
1-1/2X4-1/2	886-045C 11.17	1886-045C 11.17	886-045CP 11.17	25	0	121
1-1/2X5	886-050C 12.73	1886-050C 12.73	886-050CP 12.73	25	0	121
1-1/2X5-1/2	886-055C 12.73	1886-055C 12.73	886-055CP 12.73	25	0	121
1-1/2X6	886-060C 12.73	1886-060C 12.73	886-060CP 12.73	25	0	121
1-1/2X7	886-070C 19.09	1886-070C 19.09	886-070CP 19.09	25	0	121
1-1/2X8	886-080C 20.68	1886-080C 20.68	886-080CP 20.68	25	0	121
1-1/2X9	886-090C 21.28	1886-090C 21.28	886-090CP 21.28	25	0	121
1-1/2X10	886-100C 23.20	1886-100C 23.20	886-100CP 23.20	25	0	121
1-1/2X11	886-110C 23.93	1886-110C 23.93	886-110CP 23.93	25	0	121
1-1/2X12	886-120C 25.52	1886-120C 25.52	886-120CP 25.52	25	0	121
1-1/2X13	886-130C 30.22	1886-130C 30.22	886-130CP 30.22	25	0	121
1-1/2X14	886-140C 34.91	1886-140C 34.91	886-140CP 34.91	25	0	121
1-1/2X15	886-150C 36.96	1886-150C 36.96	886-150CP 36.96	25	0	121
1-1/2X16	886-160C 39.68	1886-160C 39.68	886-160CP 39.68	25	0	121
1-1/2X17	886-170C 40.16	1886-170C 40.16	886-170CP 40.16	25	0	121
1-1/2X18	886-180C 41.34	1886-180C 41.34	886-180CP 41.34	25	0	121
1-1/2X19	886-190C 42.98	1886-190C 42.98	886-190CP 42.98	25	0	121

CPVC Schedule 80 Nipple (continued)

Size	Threaded Both Ends	Threaded One End	Plain End	Std Pk	Mstr Pk	Prod Code
1-1/2" Diameter						
1-1/2X20	886-200C 44.59	1886-200C 44.59	886-200CP 44.59	25	0	121
1-1/2X22	886-220C 47.79	1886-220C 47.79	886-220CP 47.79	25	0	121
1-1/2X24	886-240C 51.00	1886-240C 51.00	886-240CP 51.00	25	0	121
1-1/2X30	886-300C 73.15	1886-300C 73.15	886-300CP 73.15	5	0	121
1-1/2X36	886-360C 82.69	1886-360C 82.69	886-360CP 82.69	5	0	121
1-1/2X42	886-420C 92.38	1886-420C 92.38	886-420CP 92.38	5	0	121
1-1/2X48	886-480C 101.98	1886-480C 101.98	886-480CP 101.98	5	0	121

2" Diameter

2XCLOSE	887-005C 8.81	1887-005C 8.81	887-005CP 8.81	25	0	121
2X2	887-020C 10.49	1887-020C 10.49	887-020CP 10.49	25	0	121
2X2-1/2	887-025C 10.49	1887-025C 10.49	887-025CP 10.49	25	0	121
2X3	887-030C 12.44	1887-030C 12.44	887-030CP 12.44	25	0	121
2X3-1/2	887-035C 12.44	1887-035C 12.44	887-035CP 12.44	25	0	121
2X4	887-040C 14.38	1887-040C 14.38	887-040CP 14.38	25	0	121
2X4-1/2	887-045C 14.38	1887-045C 14.38	887-045CP 14.38	25	0	121
2X5	887-050C 16.31	1887-050C 16.31	887-050CP 16.31	25	0	121
2X5-1/2	887-055C 16.31	1887-055C 16.31	887-055CP 16.31	25	0	121
2X6	887-060C 22.93	1887-060C 22.93	887-060CP 22.93	25	0	121
2X7	887-070C 23.63	1887-070C 23.63	887-070CP 23.63	25	0	121
2X8	887-080C 24.87	1887-080C 24.87	887-080CP 24.87	25	0	121
2X9	887-090C 27.04	1887-090C 27.04	887-090CP 27.04	25	0	121
2X10	887-100C 28.99	1887-100C 28.99	887-100CP 28.99	25	0	121
2X11	887-110C 30.69	1887-110C 30.69	887-110CP 30.69	25	0	121
2X12	887-120C 32.65	1887-120C 32.65	887-120CP 32.65	25	0	121
2X13	887-130C 39.20	1887-130C 39.20	887-130CP 39.20	25	0	121
2X14	887-140C 45.88	1887-140C 45.88	887-140CP 45.88	25	0	121
2X15	887-150C 47.77	1887-150C 47.77	887-150CP 47.77	25	0	121
2X16	887-160C 49.71	1887-160C 49.71	887-160CP 49.71	25	0	121
2X17	887-170C 52.92	1887-170C 52.92	887-170CP 52.92	20	0	121
2X18	887-180C 56.09	1887-180C 56.09	887-180CP 56.09	20	0	121
2X19	887-190C 59.68	1887-190C 59.68	887-190CP 59.68	25	0	121
2X20	887-200C 60.76	1887-200C 60.76	887-200CP 60.76	20	0	121
2X22	887-220C 62.21	1887-220C 62.21	887-220CP 62.21	20	0	121
2X24	887-240C 65.27	1887-240C 65.27	887-240CP 65.27	20	0	121
2X30	887-300C 95.57	1887-300C 95.57	887-300CP 95.57	5	0	121
2X36	887-360C 114.47	1887-360C 114.47	887-360CP 114.47	5	0	121
2X42	887-420C 131.79	1887-420C 131.79	887-420CP 131.79	5	0	121

Nipples PVC, CPVC & PE Nipples



CPVC Schedule 80 Nipple (continued)

Size	Threaded Both Ends	Threaded One End	Plain End	Std Pk	Mstr Pk	Prod Code
2" Diameter						
2X20	887-200C 60.76	1887-200C 60.76	887-200CP 60.76	20	0	121
2X22	887-220C 62.21	1887-220C 62.21	887-220CP 62.21	20	0	121
2X24	887-240C 65.27	1887-240C 65.27	887-240CP 65.27	20	0	121
2X30	887-300C 95.57	1887-300C 95.57	887-300CP 95.57	5	0	121
2X36	887-360C 114.47	1887-360C 114.47	887-360CP 114.47	5	0	121
2X42	887-420C 131.79	1887-420C 131.79	887-420CP 131.79	5	0	121
2X48	887-480C 149.63	1887-480C 149.63	887-480CP 149.63	5	0	121

2-1/2" Diameter

2-1/2XCLOSE	888-005C 15.99	1888-005C 15.99	888-005CP 15.99	25	0	121
2-1/2X3	888-030C 17.55	1888-030C 17.55	888-030CP 17.55	25	0	121
2-1/2X3-1/2	888-035C 21.40	1888-035C 21.40	888-035CP 21.40	25	0	121
2-1/2X4	888-040C 21.40	1888-040C 21.40	888-040CP 21.40	25	0	121
2-1/2X4-1/2	888-045C 25.57	1888-045C 25.57	888-045CP 25.57	25	0	121
2-1/2X5	888-050C 25.57	1888-050C 25.57	888-050CP 25.57	25	0	121
2-1/2X5-1/2	888-055C 30.00	1888-055C 30.00	888-055CP 30.00	25	0	121
2-1/2X6	888-060C 30.00	1888-060C 30.00	888-060CP 30.00	25	0	121
2-1/2X7	888-070C 38.37	1888-070C 38.45	888-070CP 38.37	16	0	121
2-1/2X8	888-080C 42.76	1888-080C 42.76	888-080CP 42.76	16	0	121
2-1/2X9	888-090C 46.92	1888-090C 46.92	888-090CP 46.92	25	0	121
2-1/2X10	888-100C 51.11	1888-100C 51.11	888-100CP 51.11	16	0	121
2-1/2X11	888-110C 55.54	1888-110C 55.54	888-110CP 55.54	16	0	121
2-1/2X12	888-120C 59.97	1888-120C 59.97	888-120CP 59.97	16	0	121
2-1/2X13	888-130C 68.35	1888-130C 68.35	888-130CP 68.35	25	0	121
2-1/2X14	888-140C 76.72	1888-140C 76.72	888-140CP 76.72	25	0	121
2-1/2X15	888-150C 82.01	1888-150C 82.01	888-150CP 82.01	25	0	121
2-1/2X16	888-160C 87.49	1888-160C 87.49	888-160CP 87.49	20	0	121
2-1/2X17	888-170C 90.42	1888-170C 90.42	888-170CP 90.42	20	0	121
2-1/2X18	888-180C 93.85	1888-180C 93.85	888-180CP 93.85	20	0	121
2-1/2X19	888-190C 98.03	1888-190C 98.03	888-190CP 98.03	25	0	121
2-1/2X20	888-200C 102.22	1888-200C 102.22	888-200CP 102.22	12	0	121
2-1/2X22	888-220C 111.06	1888-220C 111.06	888-220CP 111.06	25	0	121
2-1/2X24	888-240C 120.17	1888-240C 120.17	888-240CP 120.17	10	0	121
2-1/2X30	888-300C 125.79	1888-300C 125.79	888-300CP 125.79	3	0	121
2-1/2X36	888-360C 151.76	1888-360C 151.76	888-360CP 151.76	3	0	121
2-1/2X42	888-420C 174.42	1888-420C 174.42	888-420CP 174.42	3	0	121
2-1/2X48	888-480C 198.63	1888-480C 198.63	888-480CP 198.63	3	0	121

CPVC Schedule 80 Nipple

Size	Threaded Both Ends	Threaded One End	Plain End	Std Pk	Mstr Pk	Prod Code
3" Diameter						
3XCLOSE	889-005C 20.71	1889-005C 20.71	889-005CP 20.71	25	0	121
3X3	889-030C 20.71	1889-030C 20.71	889-030CP 20.71	20	0	121
3X3-1/2	889-035C 27.08	1889-035C 27.08	889-035CP 27.08	30	0	121
3X4	889-040C 27.08	1889-040C 27.08	889-040CP 27.08	30	0	121
3X4-1/2	889-045C 31.53	1889-045C 31.53	889-045CP 31.53	20	0	121
3X5	889-050C 36.01	1889-050C 36.01	889-050CP 36.01	20	0	121
3X5-1/2	889-055C 36.01	1889-055C 36.01	889-055CP 36.01	20	0	121
3X6	889-060C 42.38	1889-060C 42.38	889-060CP 42.38	20	0	121
3X7	889-070C 45.38	1889-070C 45.38	889-070CP 45.38	10	0	121
3X8	889-080C 52.29	1889-080C 52.29	889-080CP 52.29	10	0	121
3X9	889-090C 58.46	1889-090C 58.46	889-090CP 58.46	10	0	121
3X10	889-100C 68.43	1889-100C 68.43	889-100CP 68.43	10	0	121
3X11	889-110C 74.25	1889-110C 74.25	889-110CP 74.25	10	0	121
3X12	889-120C 78.74	1889-120C 78.74	889-120CP 78.74	10	0	121
3X13	889-130C 81.40	1889-130C 81.40	889-130CP 81.40	20	0	121
3X14	889-140C 90.71	1889-140C 90.71	889-140CP 90.71	20	0	121
3X15	889-150C 101.16	1889-150C 101.16	889-150CP 101.16	20	0	121
3X16	889-160C 104.59	1889-160C 104.59	889-160CP 104.59	20	0	121
3X17	889-170C 114.91	1889-170C 114.91	889-170CP 114.91	10	0	121
3X18	889-180C 116.97	1889-180C 116.97	889-180CP 116.97	10	0	121
3X19	889-190C 126.39	1889-190C 126.39	889-190CP 126.39	10	0	121
3X20	889-200C 133.85	1889-200C 133.85	889-200CP 133.85	10	0	121
3X22	889-220C 138.63	1889-220C 138.63	889-220CP 138.63	10	0	121
3X24	889-240C 144.19	1889-240C 144.19	889-240CP 144.19	10	0	121
3X30	889-300C 191.79	1889-300C 191.79	889-300CP 191.79	3	0	121
3X36	889-360C 233.88	1889-360C 233.88	889-360CP 233.88	3	0	121
3X42	889-420C 266.00	1889-420C 266.00	889-420CP 266.00	3	0	121
3X48	889-480C 288.32	1889-480C 288.32	889-480CP 288.32	3	0	121

4" Diameter

4XCLOSE	890-005C 31.93	1890-005C 31.93	890-005CP 31.93	25	0	121
4X3	890-030C 36.47	1890-030C 36.47	890-030CP 36.47	25	0	121
4X3-1/2	890-035C 36.47	1890-035C 36.47	890-035CP 36.47	25	0	121
4X4	890-040C 38.33	1890-040C 38.33	890-040CP 38.33	18	0	121
4X4-1/2	890-045C 44.64	1890-045C 44.64	890-045CP 44.64	12	0	121
4X5	890-050C 44.64	1890-050C 44.64	890-050CP 44.64	12	0	121
4X5-1/2	890-055C 51.01	1890-055C 51.01	890-055CP 51.01	12	0	121
4X6	890-060C 60.60	1890-060C 60.60	890-060CP 60.60	12	0	121



Nipples PVC, CPVC & PE Nipples

CPVC Schedule 80 Nipple (continued)

Size	Threaded Both Ends	Threaded One End	Plain End	Std Pk	Mstr Pk	Prod Code
4" Diameter						
4X3-1/2	890-035C 36.47	1890-035C 36.47	890-035CP 36.47	25	0	121
4X4	890-040C 38.33	1890-040C 38.33	890-040CP 38.33	18	0	121
4X4-1/2	890-045C 44.64	1890-045C 44.64	890-045CP 44.64	12	0	121
4X5	890-050C 44.64	1890-050C 44.64	890-050CP 44.64	12	0	121
4X5-1/2	890-055C 51.01	1890-055C 51.01	890-055CP 51.01	12	0	121
4X6	890-060C 60.60	1890-060C 60.60	890-060CP 60.60	12	0	121
4X7	890-070C 64.03	1890-070C 64.03	890-070CP 64.03	16	0	121
4X8	890-080C 76.60	1890-080C 76.60	890-080CP 76.60	16	0	121
4X9	890-090C 82.95	1890-090C 82.95	890-090CP 82.95	16	0	121
4X10	890-100C 89.36	1890-100C 89.36	890-100CP 89.36	16	0	121
4X11	890-110C 98.60	1890-110C 98.60	890-110CP 98.60	16	0	121
4X12	890-120C 102.06	1890-120C 102.06	890-120CP 102.06	16	0	121
4X13	890-130C 113.16	1890-130C 113.16	890-130CP 113.16	16	0	121
4X14	890-140C 121.79	1890-140C 121.79	890-140CP 121.79	16	0	121
4X15	890-150C 137.20	1890-150C 137.20	890-150CP 137.20	12	0	121
4X16	890-160C 153.18	1890-160C 153.18	890-160CP 153.18	12	0	121
4X17	890-170C 159.55	1890-170C 159.55	890-170CP 159.55	12	0	121
4X18	890-180C 165.92	1890-180C 165.92	890-180CP 165.92	4	0	121
4X19	890-190C 178.66	1890-190C 178.66	890-190CP 178.66	12	0	121
4X20	890-200C 185.28	1890-200C 185.28	890-200CP 185.28	8	0	121
4X22	890-220C 189.68	1890-220C 189.68	890-220CP 189.68	8	0	121
4X24	890-240C 206.68	1890-240C 206.68	890-240CP 206.68	4	0	121
4X30	890-300C 274.42	1890-300C 274.39	890-300CP 274.42	3	0	121
4X36	890-360C 334.55	1890-360C 334.55	890-360CP 334.55	3	0	121
4X42	890-420C 370.95	1890-420C 370.95	890-420CP 370.95	3	0	120
4X48	890-480C 401.48	1890-480C 401.48	890-480CP 401.48	3	0	121

6" Diameter

6XCLOSE	892-005C 75.56	1892-005C 75.56	892-005CP 75.56	1	8	121
6X3	892-030C 85.77	1892-030C 85.77	892-030CP 85.77	1	4	121
6X4	892-040C 117.32	1892-040C 117.32	892-040CP 117.32	1	0	121
6X4-1/2	892-045C 122.74	1892-045C 122.74	892-045CP 122.74	1	4	121
6X5	892-050C 131.57	1892-050C 131.57	892-050CP 131.57	1	2	121
6X5-1/2	892-055C 139.36	1892-055C 139.99	892-055CP 139.36	1	2	121
6X6	892-060C 153.55	1892-060C 153.55	892-060CP 153.55	1	0	121
6X7	892-070C 162.82	1892-070C 162.82	892-070CP 162.82	1	2	121
6X8	892-080C 180.55	1892-080C 180.55	892-080CP 180.55	1	0	121
6X9	892-090C 196.09	1892-090C 196.09	892-090CP 196.09	1	0	121

CPVC Schedule 80 Nipple (continued)

Size	Threaded Both Ends	Threaded One End	Plain End	Std Pk	Mstr Pk	Prod Code
6" Diameter						
6X10	892-100C 211.60	1892-100C 211.60	892-100CP 211.60	1	0	121
6X11	892-110C 227.14	1892-110C 227.14	892-110CP 227.14	1	0	121
6X12	892-120C 242.65	1892-120C 242.65	892-120CP 242.65	1	0	121
6X13	892-130C 258.19	1892-130C 258.19	892-130CP 258.19	1	0	121
6X14	892-140C 273.74	1892-140C 273.74	892-140CP 273.74	1	0	121
6X15	892-150C 289.24	1892-150C 289.24	892-150CP 289.24	1	0	121
6X16	892-160C 304.78	1892-160C 304.52	892-160CP 304.78	1	0	121
6X17	892-170C 320.32	1892-170C 320.32	892-170CP 320.32	1	0	121
6X18	892-180C 330.73	1892-180C 330.73	892-180CP 330.73	1	6	121
6X19	892-190C 351.41	1892-190C 351.41	892-190CP 351.41	1	0	121
6X20	892-200C 366.89	1892-200C 366.89	892-200CP 366.89	1	0	121
6X22	892-220C 397.96	1892-220C 397.96	892-220CP 397.96	1	0	121
6X24	892-240C 458.37	1892-240C 458.37	892-240CP 458.37	1	3	121
6X30	892-300C 522.18	1892-300C 522.18	892-300CP 522.18	1	0	121
6X36	892-360C 615.38	1892-360C 615.38	892-360CP 615.38	1	0	121
6X42	892-420C 708.56	1892-420C 708.56	892-420CP 708.56	1	0	121
6X48	892-480C 801.75	1892-480C 801.75	892-480CP 801.75	1	0	121

8" Diameter

8XCLOSE	893-005C 110.80	1893-005C 110.80	893-005CP 110.80	2	0	121
8X4-1/2	893-045C 142.73	1893-045C 142.73	893-045CP 142.73	1	0	121
8X5	893-050C 153.36	1893-050C 153.36	893-050CP 153.36	1	0	121
8X5-1/2	893-055C 164.01	1893-055C 164.01	893-055CP 164.01	1	0	121
8X6	893-060C 174.64	1893-060C 174.64	893-060CP 174.64	1	0	121
8X7	893-070C 195.94	1893-070C 195.94	893-070CP 195.94	1	0	121
8X8	893-080C 217.22	1893-080C 217.22	893-080CP 217.22	4	0	121
8X9	893-090C 240.35	1893-090C 240.35	893-090CP 240.35	1	0	121
8X10	893-100C 259.80	1893-100C 259.80	893-100CP 259.80	1	0	121
8X11	893-110C 281.07	1893-110C 281.07	893-110CP 281.07	1	0	121
8X12	893-120C 308.71	1893-120C 308.71	893-120CP 308.71	1	0	121
8X13	893-130C 323.65	1893-130C 323.65	893-130CP 323.65	1	0	121
8X14	893-140C 344.95	1893-140C 344.95	893-140CP 344.95	1	0	121
8X15	893-150C 366.22	1893-150C 366.22	893-150CP 366.22	1	0	121
8X16	893-160C 387.52	1893-160C 387.52	893-160CP 387.52	1	0	121
8X17	893-170C 408.80	1893-170C 408.53	893-170CP 408.80	1	0	121
8X18	893-180C 430.07	1893-180C 430.07	893-180CP 430.07	4	0	121
8X19	893-190C 451.39	1893-190C 451.39	893-190CP 451.39	1	0	121
8X20	893-200C 472.67	1893-200C 472.67	893-200CP 472.67	2	0	121

Nipples PVC, CPVC & PE Nipples



CPVC Schedule 80 Nipple (continued)

Size	Threaded Both Ends	Threaded One End	Plain End	Std Pk	Mstr Pk	Prod Code
8" Diameter						
8X15	893-150C 366.22	1893-150C 366.22	893-150CP 366.22	1	0	121
8X16	893-160C 387.52	1893-160C 387.52	893-160CP 387.52	1	0	121
8X17	893-170C 408.80	1893-170C 408.53	893-170CP 408.80	1	0	121
8X18	893-180C 430.07	1893-180C 430.07	893-180CP 430.07	4	0	121
8X19	893-190C 451.39	1893-190C 451.39	893-190CP 451.39	1	0	121
8X20	893-200C 472.67	1893-200C 472.67	893-200CP 472.67	2	0	121
8X22	893-220C 493.96	1893-220C 493.96	893-220CP 493.96	1	0	121
8X24	893-240C 515.24	1893-240C 515.24	893-240CP 515.24	2	2	121
8X30	893-300C 742.57	1893-300C 742.57	893-300CP 742.57	4	0	121
8X36	893-360C 905.78	1893-360C 905.78	893-360CP 905.78	4	0	121
8X42	893-420C 958.58	1893-420C 958.58	893-420CP 958.58	1	0	121
8X48	893-480C 1051.26	1893-480C 1051.26	893-480CP 1051.26	1	0	121

10" Diameter

10XCLOSE	894-005C 154.63	1894-005C 154.63	894-005CP 154.63	1	0	121
10X4-1/2	894-045C 208.47	1894-045C 208.47	894-045CP 208.47	1	0	121
10X5	894-050C 226.39	1894-050C 226.39	894-050CP 226.39	1	0	121
10X5-1/2	894-055C 244.36	1894-055C 244.36	894-055CP 244.36	1	0	121
10X6	894-060C 262.31	1894-060C 262.31	894-060CP 262.31	1	0	121
10X7	894-070C 298.21	1894-070C 298.21	894-070CP 298.21	1	0	121
10X8	894-080C 334.11	1894-080C 334.11	894-080CP 334.11	1	0	121
10X9	894-090C 370.00	1894-090C 370.00	894-090CP 370.00	1	0	121
10X10	894-100C 405.91	1894-100C 405.91	894-100CP 405.91	1	0	121
10X11	894-110C 441.81	1894-110C 441.81	894-110CP 441.81	1	0	121
10X12	894-120C 477.72	1894-120C 477.72	894-120CP 477.72	1	0	121
10X13	894-130C 525.89	1894-130C 525.89	894-130CP 525.89	1	0	121
10X14	894-140C 558.64	1894-140C 558.64	894-140CP 558.64	1	0	121
10X15	894-150C 585.41	1894-150C 585.41	894-150CP 585.41	1	0	121
10X16	894-160C 657.03	1894-160C 657.03	894-160CP 657.03	1	0	121
10X17	894-170C 663.81	1894-170C 663.81	894-170CP 663.81	1	0	121
10X18	894-180C 693.09	1894-180C 693.09	894-180CP 693.09	1	0	121
10X19	894-190C 760.53	1894-190C 760.53	894-190CP 760.53	1	0	121
10X20	894-200C 801.32	1894-200C 801.32	894-200CP 801.32	1	0	121
10X22	894-220C 840.21	1894-220C 840.21	894-220CP 840.21	1	0	121
10X24	894-240C 991.55	1894-240C 991.55	894-240CP 991.55	1	2	121
10X30	894-300C 1074.47	1894-300C 1074.47	894-300CP 1074.47	1	0	121
10X36	894-360C 1309.05	1894-360C 1309.05	894-360CP 1309.05	1	0	121
10X42	894-420C 1526.43	1894-420C 1526.43	894-420CP 1526.43	1	0	121

CPVC Schedule 80 Nipple (continued)

Size	Threaded Both Ends	Threaded One End	Plain End	Std Pk	Mstr Pk	Prod Code
10" Diameter						
10X48	894-480C 1726.49	1894-480C 1726.49	894-480CP 1726.49	1	0	121
12" Diameter						
12XCLOSE	895-005C 217.04	1895-005C 217.04	895-005CP 217.04	1	0	121
12X5	895-050C 290.24	1895-050C 290.24	895-050CP 290.24	1	0	121
12X5-1/2	895-055C 314.55	1895-055C 314.55	895-055CP 314.55	1	0	121
12X6	895-060C 337.78	1895-060C 337.78	895-060CP 337.78	1	0	121
12X7	895-070C 387.57	1895-070C 387.57	895-070CP 387.57	1	0	121
12X8	895-080C 436.24	1895-080C 436.24	895-080CP 436.24	1	0	121
12X9	895-090C 433.31	1895-090C 433.31	895-090CP 433.31	1	0	121
12X10	895-100C 533.56	1895-100C 533.56	895-100CP 533.56	1	0	121
12X11	895-110C 582.23	1895-110C 582.23	895-110CP 582.23	1	0	121
12X12	895-120C 630.88	1895-120C 630.88	895-120CP 630.88	1	0	121
12X13	895-130C 679.54	1895-130C 679.54	895-130CP 679.54	1	0	121
12X14	895-140C 728.23	1895-140C 728.23	895-140CP 728.23	1	0	121
12X15	895-150C 776.86	1895-150C 776.86	895-150CP 776.86	1	0	121
12X16	895-160C 825.54	1895-160C 825.54	895-160CP 825.54	1	0	121
12X17	895-170C 874.20	1895-170C 874.20	895-170CP 874.20	1	0	121
12X18	895-180C 922.86	1895-180C 922.86	895-180CP 922.86	1	0	121
12X19	895-190C 971.52	1895-190C 971.52	895-190CP 971.52	1	0	121
12X20	895-200C 1020.20	1895-200C 1020.20	895-200CP 1020.20	1	0	121
12X22	895-220C 1068.85	1895-220C 1068.85	895-220CP 1068.85	1	0	121
12X24	895-240C 1316.74	1895-240C 1316.74	895-240CP 1316.74	1	0	121
12X30	895-300C 1527.00	1895-300C 1527.00	895-300CP 1527.00	1	0	121
12X36	895-360C 1798.81	1895-360C 1798.81	895-360CP 1798.81	1	0	121
12X42	895-420C 2010.58	1895-420C 2010.58	895-420CP 2010.58	1	0	121
12X48	895-480C 2382.77	1895-480C 2382.77	895-480CP 2382.77	1	0	121



Nipples PVC, CPVC & PE Nipples & PE Nipples

Machined CPVC Nipple Options -Threaded Both Ends (TBE)

The following nipples are normally injection molded, but are optionally available as machined nipples listed below. All other nipples are normally machined.

Part Number	Size	Std Pk	Mstr Ctn	Prod Code	Price Each
-------------	------	--------	----------	-----------	------------

CPVC Schedule 80 Machined Nipples

1/4" Diameter



880-005CM	1/4XCLOSE	25	1200	121	4.76
-----------	-----------	----	------	-----	------

CPVC Schedule 80 Machined Nipples

1/2" Diameter



882-020CM	1/2X2	25	300	121	3.95
882-030CM	1/2X3	25	300	121	4.93
882-040CM	1/2X4	25	150	121	5.61

Part Number	Size	Std Pk	Mstr Ctn	Prod Code	Price Each
-------------	------	--------	----------	-----------	------------

CPVC Schedule 80 Machined Nipples

3/4" Diameter



883-030CM	3/4X3	25	300	121	7.14
883-060CM	3/4X6	25	200	121	10.00

CPVC Schedule 80 Machined Nipples

1" Diameter



884-005CM	1XCLOSE	25	300	121	7.52
884-020CM	1X2	25	300	121	7.02

PE Nipples

Polyethylene Schedule 40 Nipple

Part Number	Size	Std Pk	Mstr Ctn	Prod Code	Price Each
-------------	------	--------	----------	-----------	------------

1/2" Diameter

P42-005	1/2XCLOSE	25	450	120	.94
P42-015	1/2X1-1/2	25	300	120	.94
P42-020	1/2X2	25	300	120	.94
P42-025	1/2X2-1/2	25	300	120	1.11
P42-030	1/2X3	25	300	120	1.11
P42-035	1/2X3-1/2	25	300	120	1.18
P42-040	1/2X4	25	300	120	1.18
P42-045	1/2X4-1/2	25	300	120	1.34
P42-050	1/2X5	25	300	120	1.34
P42-055	1/2X5-1/2	25	300	120	1.56
P42-060	1/2X6	25	300	120	1.56
P42-070	1/2X7	25	200	120	2.34
P42-080	1/2X8	25	100	120	2.38
P42-090	1/2X9	25	0	120	2.48
P42-100	1/2X10	25	0	120	2.53
P42-110	1/2X11	25	0	120	2.65
P42-120	1/2X12	25	0	120	2.66
P42-140	1/2X14	100	0	120	3.67
P42-150	1/2X15	100	0	120	4.07
P42-160	1/2X16	100	0	120	4.44
P42-180	1/2X18	100	0	120	4.81
P42-240	1/2X24	100	0	120	7.02

Polyethylene Schedule 40 Nipple

Part Number	Size	Std Pk	Mstr Ctn	Prod Code	Price Each
-------------	------	--------	----------	-----------	------------

3/4" Diameter

P43-005	3/4XCLOSE	25	150	120	1.11
P43-020	3/4X2	25	300	120	1.11
P43-025	3/4X2-1/2	25	300	120	1.56
P43-030	3/4X3	25	300	120	1.56
P43-035	3/4X3-1/2	25	300	120	1.74
P43-040	3/4X4	25	300	120	1.74
P43-045	3/4X4-1/2	25	200	120	1.82
P43-050	3/4X5	25	200	120	1.82
P43-055	3/4X5-1/2	25	200	120	1.98
P43-060	3/4X6	25	200	120	1.98
P43-070	3/4X7	25	200	120	6.09
P43-080	3/4X8	25	0	120	6.37

Polyethylene Schedule 40 Nipple (continued)

Part Number	Size	Std Pk	Mstr Ctn	Prod Code	Price Each
-------------	------	--------	----------	-----------	------------

3/4" Diameter

P43-090	3/4X9	25	0	120	6.95
P43-100	3/4X10	25	0	120	7.49
P43-110	3/4X11	25	0	120	7.86
P43-120	3/4X12	25	0	120	8.06

Polyethylene Cut-Off Nipples

Part Number	Size	Std Pk	Mstr Ctn	Prod Code	Price Each
491-060	1/2" MPTx6" Cut-Off	50	400	120	.94
492-060	1/2"x3/4" MPTx6" Cut-Off	50	350	120	1.41
493-060	3/4" MPTx6" Cut-Off	50	300	120	1.41

Nipples
PE Nipples & Four-In-One • Cut-Off Nipples



PE Nipples

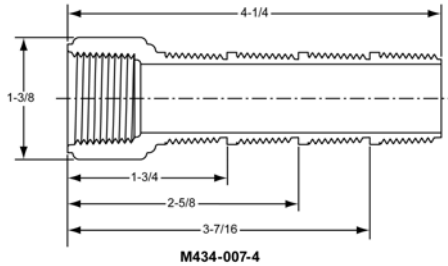
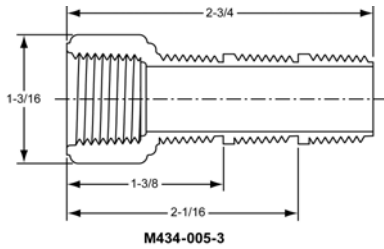

Polyethylene Cut-Off Riser Extension

Part Number	Size	Std Pk	Mstr Ctn	Prod Code	Price Each
-------------	------	--------	----------	-----------	------------

FIPT x MIPT Cut-Off

(1/2" = 3 - Section Cut-Off; 3/4" = 4 - Section Cut-Off)

M434-005-3	1/2X3	50	600	120	1.42
M434-007-4	3/4X4	50	0	120	1.88

Four-In-One • Cut-Off Nipples

- High quality polyethylene construction
- Reduces inventory
- Reduces contractor down time
- Choice of sizes from just one nipple
- Eliminates waste

Four-In-One Cut-Off Nipple

Part Number	Size	Std Pk	Mstr Ctn	Prod Code	Price Each
M481-005	1/2X6	50	350	123	1.08
M481-007	3/4X6	25	200	123	1.55

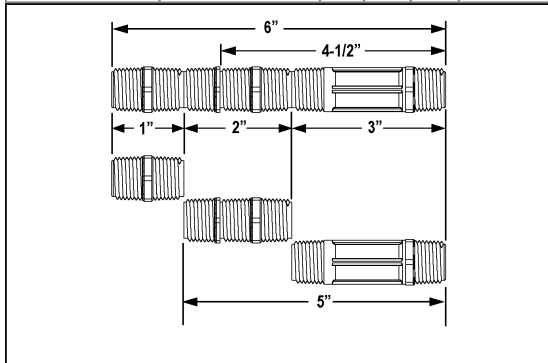

Four-In-One Cut-Off Nipple - Reducing

Part Number	Size	Std Pk	Mstr Ctn	Prod Code	Price Each
M481-101	3/4X1/2X6	50	300	123	1.18

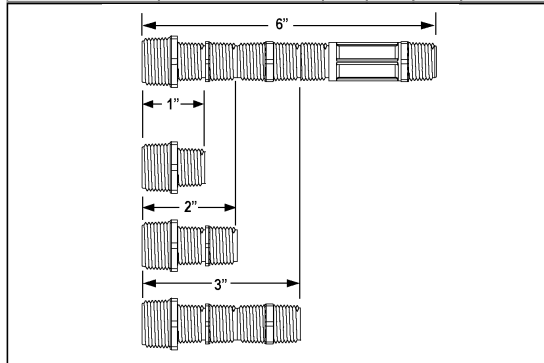



Nipples Grooved Nipples

PVC Schedule 80 Grooved Nipple

Size	Groove X Groove	Plain X Groove	Thread X Groove	Std Pk	Mstr Pk	Prod Code
------	-----------------	----------------	-----------------	--------	---------	-----------

1-1/2" Diameter

1-1/2X3	886-030GG 3.13	886-030PG 3.13	886-030TG 3.13	25	0	120
1-1/2X4	886-040GG 5.39	886-040PG 4.89	886-040TG 5.39	25	0	120
1-1/2X6	886-060GG 8.27	886-060PG 8.27	886-060TG 8.27	25	0	120

2" Diameter

2X3	887-030GG 6.83	887-030PG 6.83	887-030TG 6.83	25	0	120
2X4	887-040GG 7.91	887-040PG 7.91	887-040TG 7.91	25	0	120
2X6	887-060GG 10.49	887-060PG 10.79	887-060TG 10.79	25	0	120

3" Diameter

3X3	889-030GG 14.55	889-030PG 14.55	889-030TG 17.00	20	0	120
3X4	889-040GG 19.44	889-040PG 19.44	889-040TG 19.44	30	0	120
3X6	889-060GG 27.23	889-060PG 27.23	889-060TG 27.23	20	0	120

4" Diameter

4X3	890-030GG 22.85	890-030PG 22.85	890-030TG 22.85	25	0	120
4X4	890-040GG 30.25	890-040PG 30.25	890-040TG 30.25	18	0	120
4X6	890-060GG 30.45	890-060PG 30.45	890-060TG 30.45	12	0	120

6" Diameter

6X3	892-030GG 25.68	892-030PG 25.68	892-030TG 25.68	1	4	121
6X4	892-040GG 30.57	892-040PG 30.57	892-040TG 30.57	4	0	120
6X6	892-060GG 44.23	892-060PG 44.23	892-060TG 44.23	2	0	120